



Revolution Oven (GAS MODEL) Parts Manual

RE-4-8

RE-4-12

RE-4-16

RE-8-16

RE-8-24

RE-8-32



A

#	Part #	Description	Model
A	RE800610	6 MONTHS MAINTENANCE KIT	ALL

Description

MAINTENANCE KIT



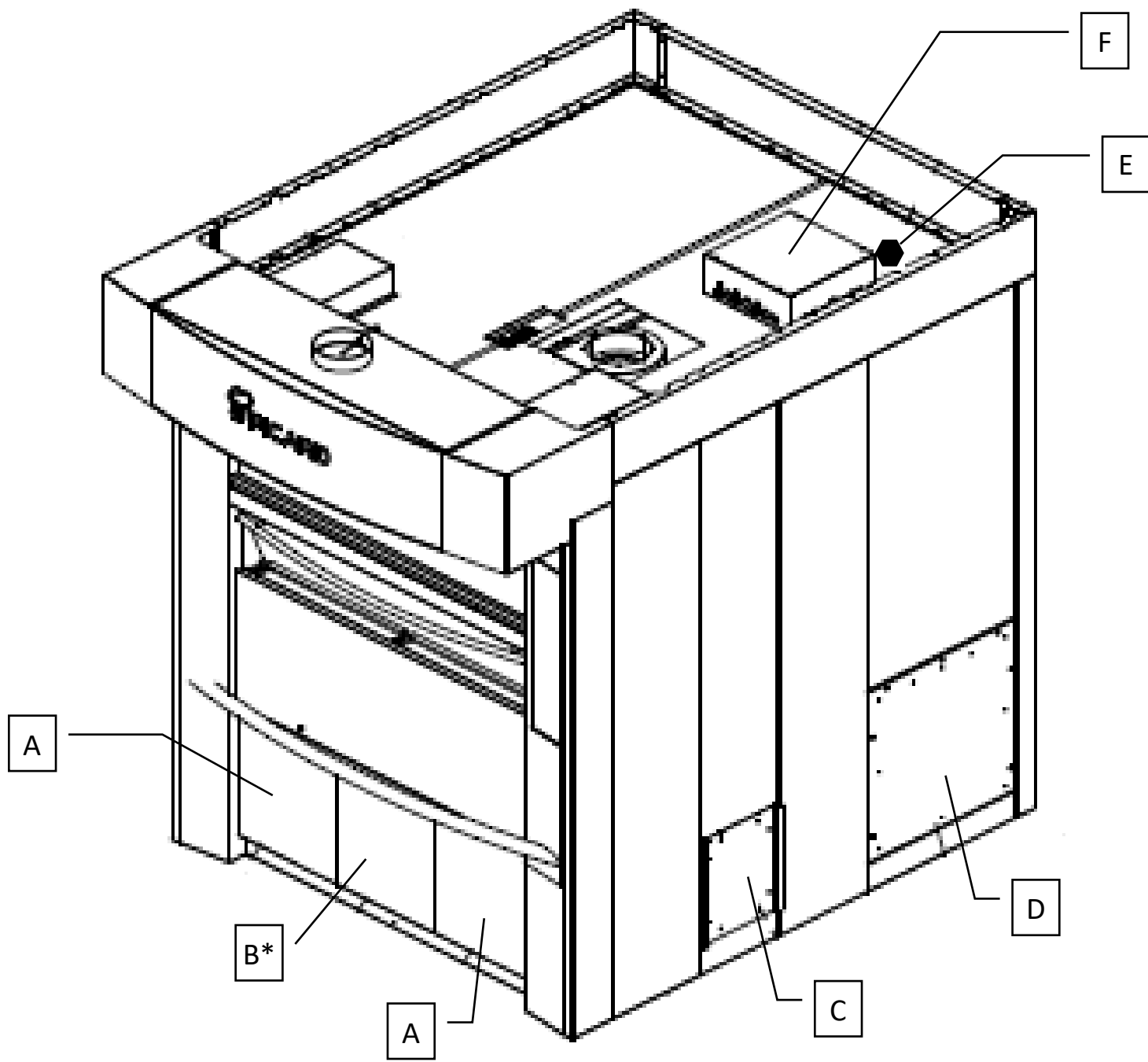

#	Part #	Description	Model
A	RE800151A	FRONT SIDE DRESSING PANEL	ALL
B*	RE800151B	FRONT CENTER DRESSING PANEL	RE816 = 0 RE824 = 1 RE832 = 2
C	RE800026	CLEANING HOLE COVER	ALL
D	RE800028	MANHOLE	ALL
E	EL18-0003	OCTOGONAL BOX	ALL
F	RE800073	ELECTRICAL BOX ASSEMBLY	ALL

* MODEL SPECIFIC

Description

PANELS



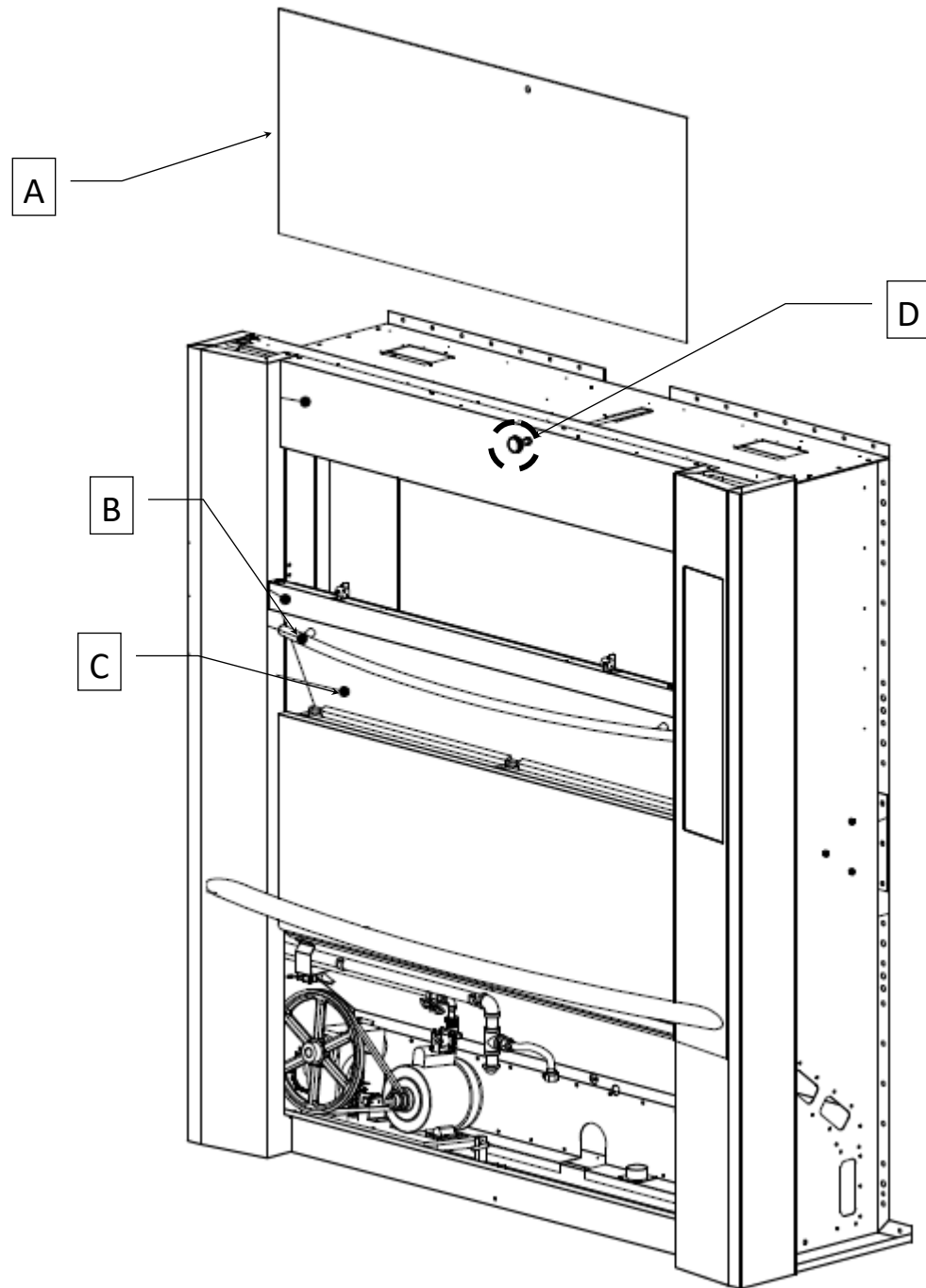

#	Part #	Description	Model
A	RE8"XX"900	GLASS	*
B	RE8"XX"049	DOOR HANDLE	*
C	RE8"XX"132	OVEN DOOR	*
D	RE800440	VENTILATION KNOB	ALL

* MODEL SPECIFIC

Description

OVEN FRONT



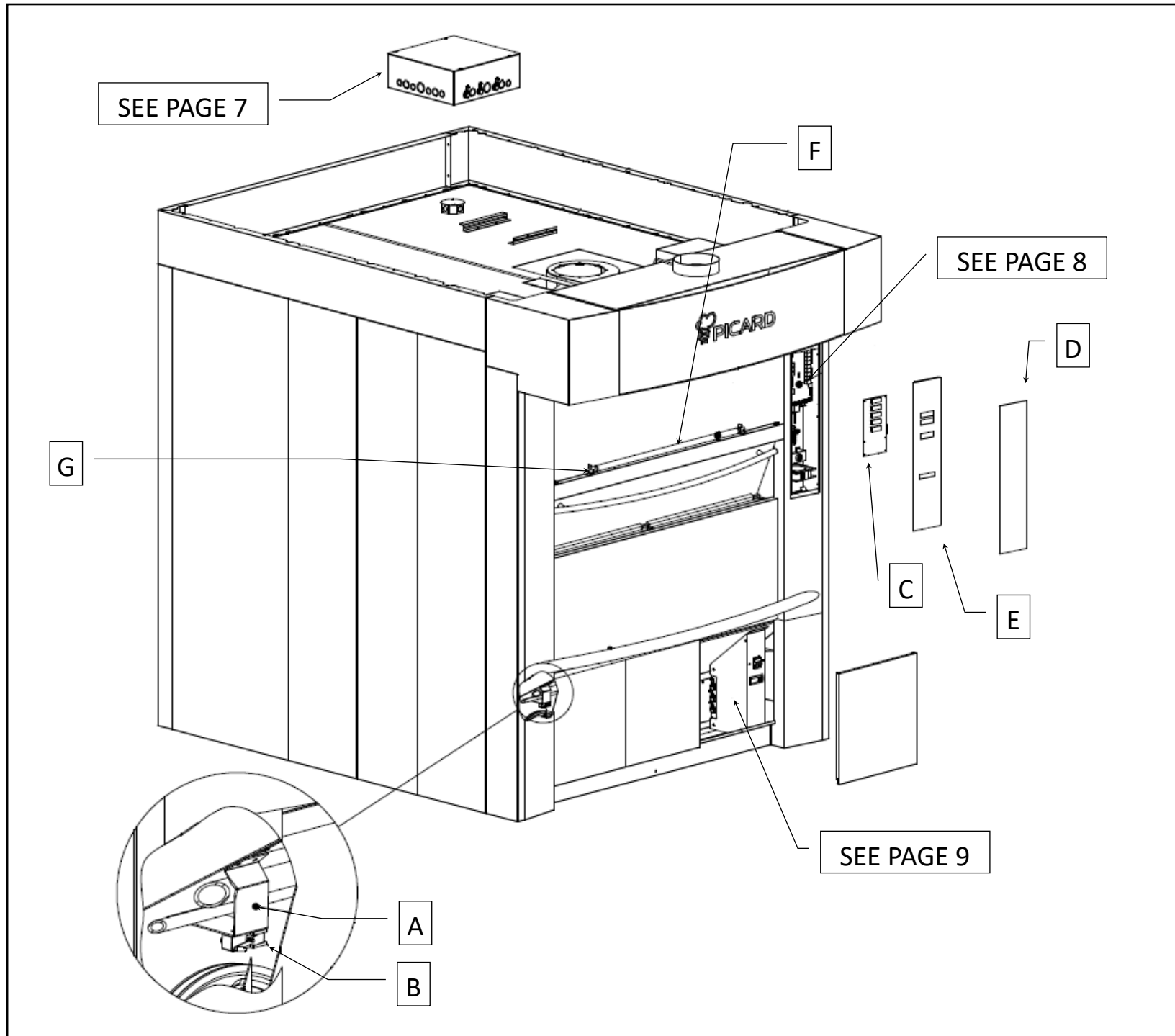

#	Part #	Description	Model
A	RE800167	LIMIT SWITCH SUPPORT	ALL
B	EL66-0017	LIMIT SWITCH	ALL
C	EL02-0124	DISPLAY CARD	ALL
D	RE800705	DIGITAL CONTROL	ALL
E	RE800061	CONTROL PANEL	ALL
F*	EL37-0004	FLUORESCENT LAMP	RE48 = 1x RE816 = 1x RE416 = 2X RE832 = 2X
F*	EL37-0021	FLUORESCENT LAMP	RE-4-12 = 1x RE-8-24 = 1x
G	RE11-0006-A	WIRING AND LAMP SOCKET	ALL

* MODEL SPECIFIC

Description

ELECTRICAL COMPARTMENTS 1-4



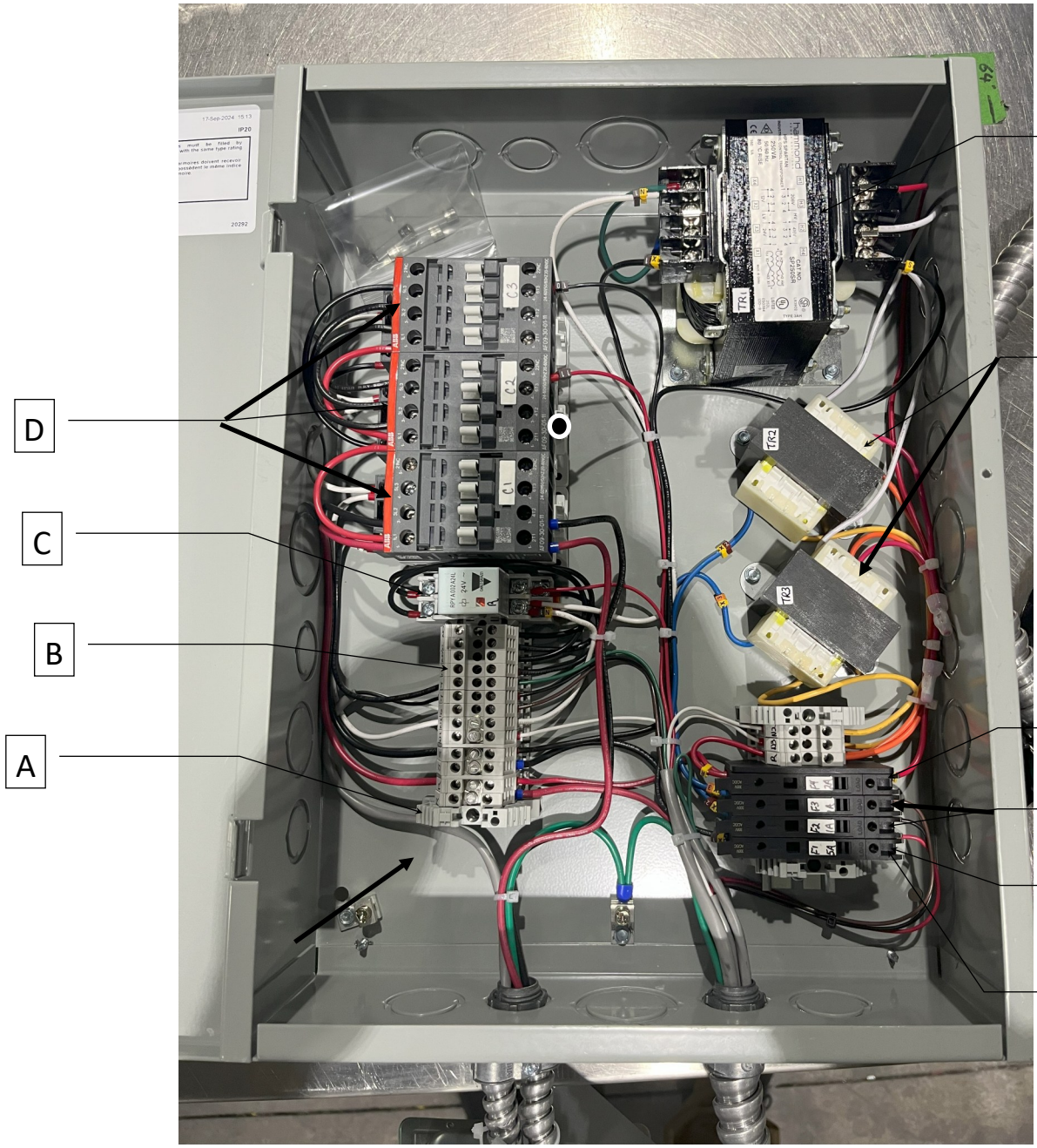

#	Part #	Description	Model
A	028-2008	TERMINAL STOPPER	ALL
B	EL05-0001	TERMINAL	ALL
C	EL03-0052	RELAY 10A 24VAC	ALL
D	EL03-0102	CONTACTOR	ALL
E	EL40-0037	TRANSFORMER 40VA 208/240V - 24VAC 50/60Hz	ALL
F	EL40-0018	TRANSFORMER 250VA 208/416 - 12/24V 50/60HZ	ALL
G	EL36-0012	FUSE HOLDER	ALL
H	EL36-0006	FUSE MINI 5A 1/4" X 1-1/4"	ALL
I	EL36-0044	FUSE MINI 1A 1/4" X 1-1/4"	ALL
J	EL36-0025	FUSE MINI 2A	ALL

* MODEL SPECIFIC

Description
ELECTRICAL COMPARTMENTS 2-4 (ELECTRICAL BOX)



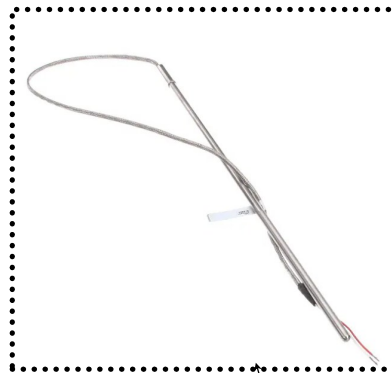
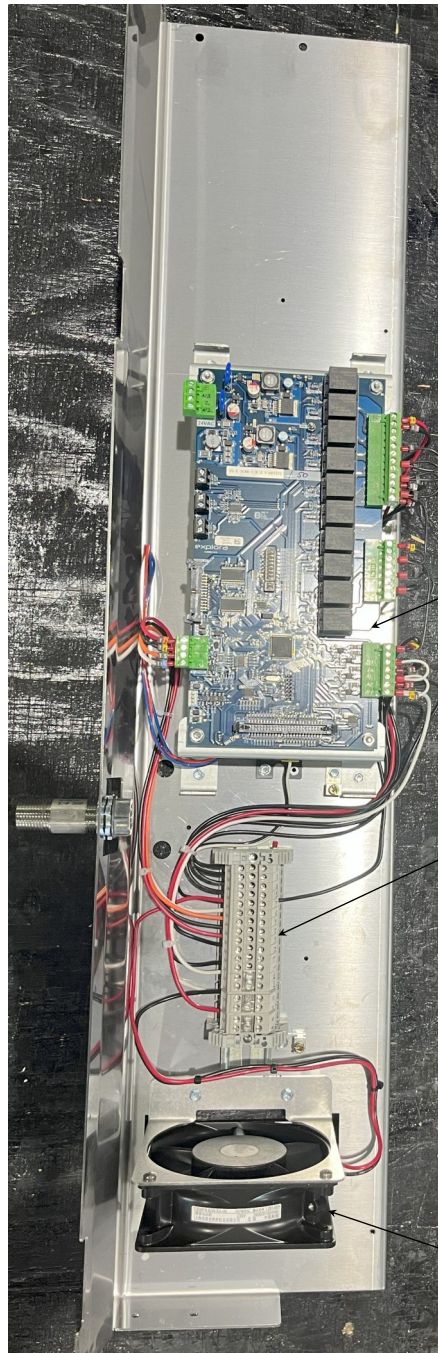

A

D

B

C

#	Part #	Description	Model
A	EL02-0123	CONTROL BOARD	ALL
B	EL05-0001	TERMINAL	ALL
C	VE68-0036	4 "DIA, 230VAC, 110 CFM	ALL
D	EL64-0101	THERMOCOUPLE TYPE « J », 24" WIRE, 17" PROBE	ALL

* MODEL SPECIFIC

Description

ELECTRICAL COMPARTMENTS 3-4 (MAIN ELECTRICAL PANEL)



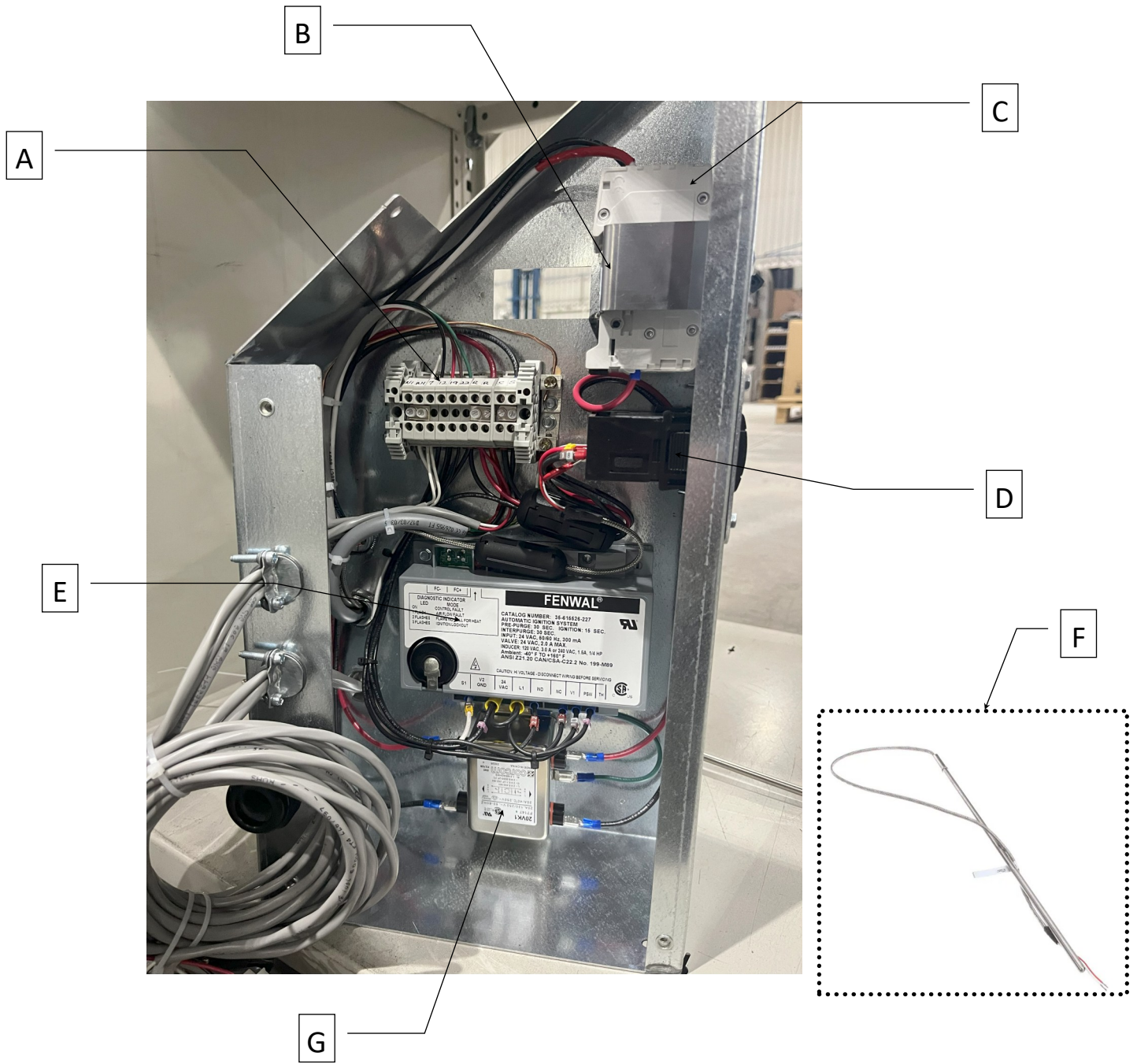

#	Part #	Description	Model
A	EL05-0001	TERMINAL	ALL
B	RE800209	BREAKER SUPPORT	ALL
C	EL36-0087	BREAKER	ALL
D	EL02-0102	HIGH LIMIT	ALL
E	EL02-0165	IGNITION MODULE	ALL
F	EL64-0102	THERMOCOUPLE TYPE « J », 96" WIRE, 17" PROBE	ALL
G	EL02-0176	LINE FILTER 20A	ALL

Description
 ELECTRICAL COMPARTMENTS 4-4 (BOTTOM ELECTRICAL PANEL)



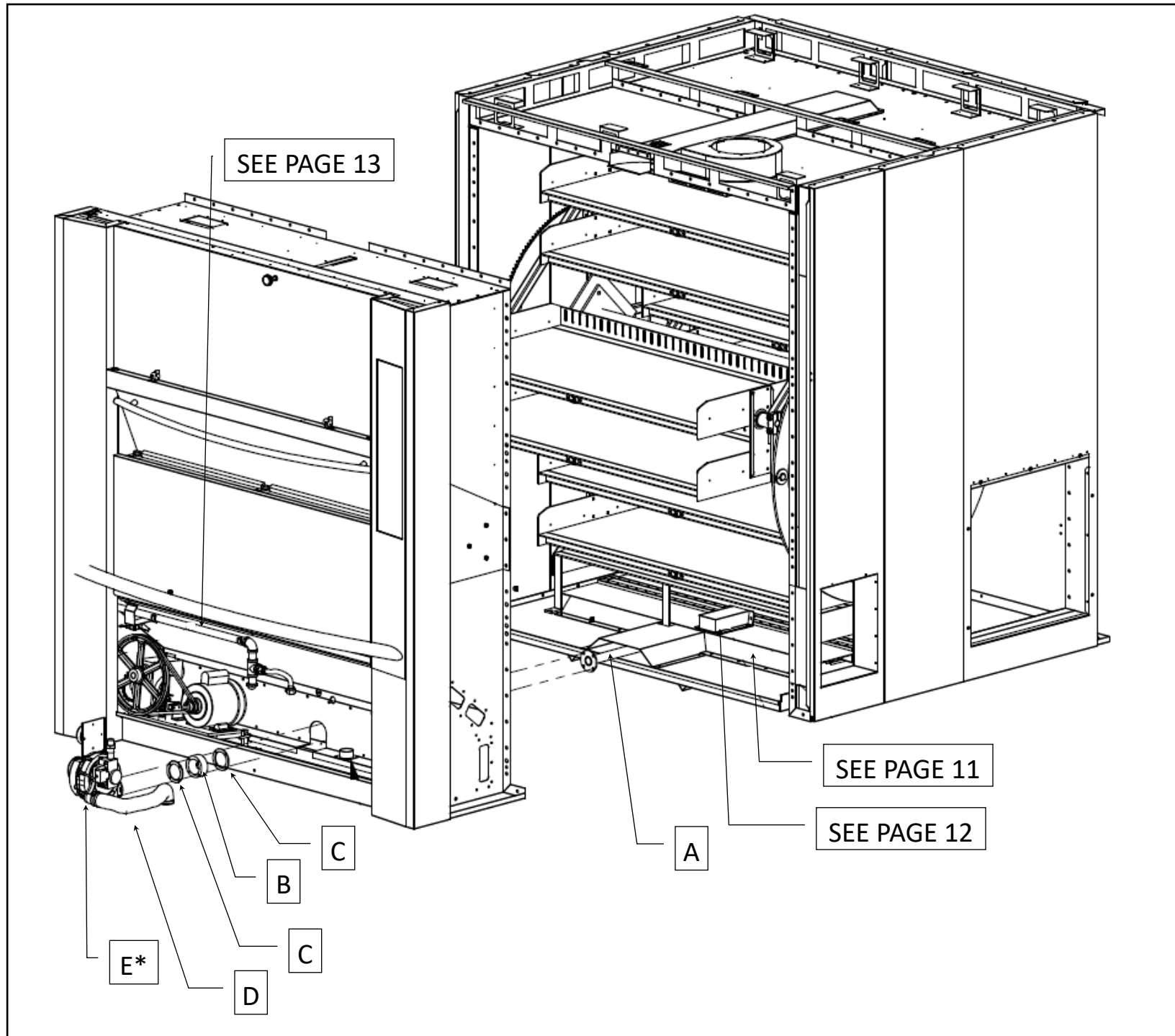

#	Part #	Description	Model
A	RE8"XX"065	BURNER & TUBE	*
B	RE800412	BURNER BLOWER ADAPTOR	ALL
C	RE800418	BURNER BLOWER GASKET	ALL
D	DI91-0033	AIR INTAKE FLEXIBLE TUBE	ALL
E*	RE11-0007-A	BURNER BLOWER RE-8-16 NATURAL GAS	*
E*	RE11-0008-A	BURNER BLOWER RE-8-16 PROPANE	*
E*	RE11-0009-A	BURNER BLOWER RE-8-24 PROPANE	*
E*	RE11-0010-A	BURNER BLOWER RE-8-32 PROPANE	*
E*	RE11-0012-A	BURNER BLOWER RE-8-24 NATURAL GAS	*
E*	RE11-0013-A	BURNER BLOWER RE-8-32 NATURAL GAS	*
F	RE11-0002-A	BURNER BLOWER POWER PIGTAIL	ALL
G	RE11-0003-A	BURNER BLOWER CONTROL PIGTAIL	ALL

Description
BURNER & BLOWER



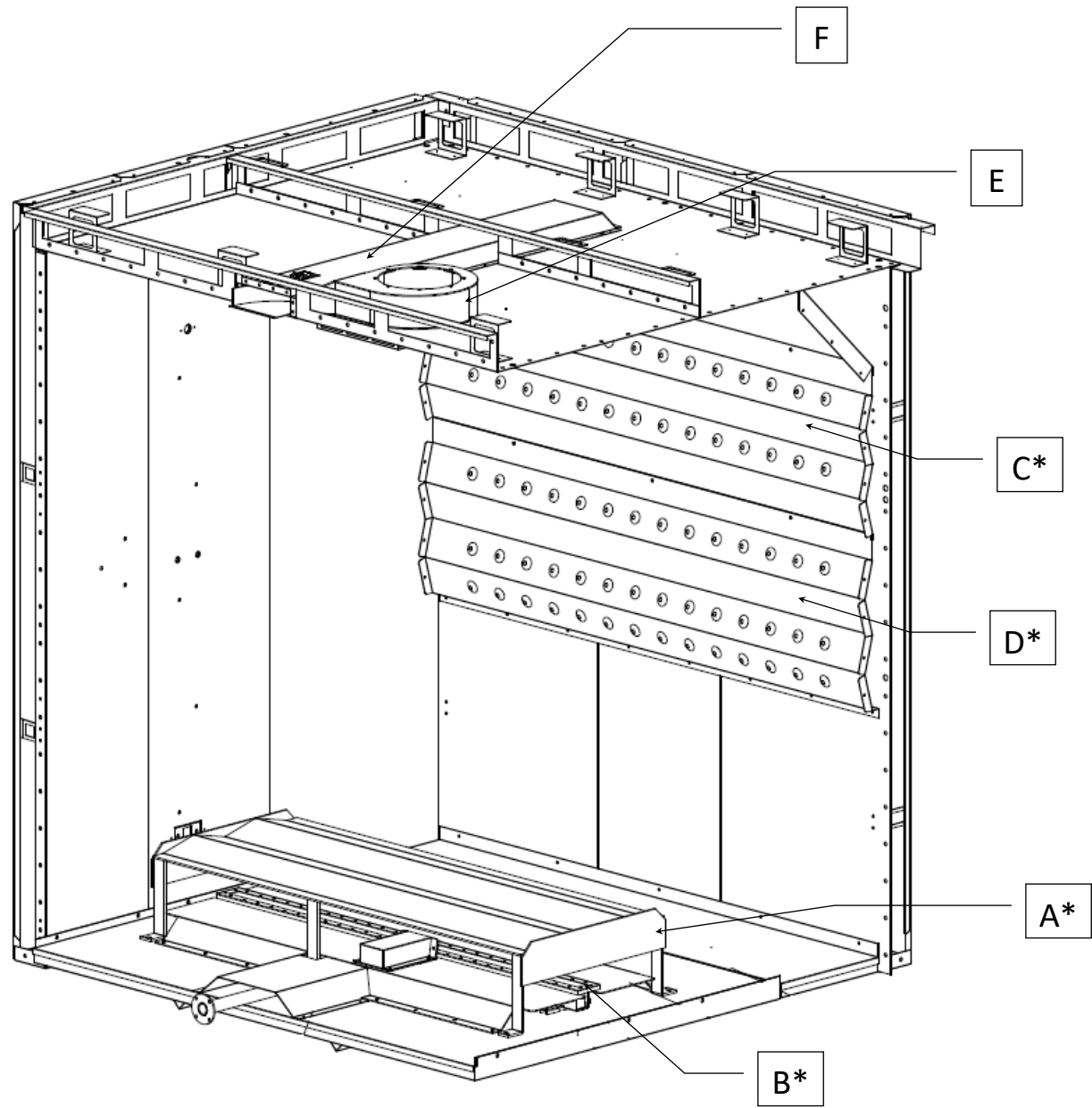

#	Part #	Description	Model
A*	RE8"XX"057	FLAME DEFLECTOR	*
B*	RE8"XX"065	BURNER & TUBE	*
C*	RE8"XX"150B	VENTILATION PLATE (TOP)	*
D*	RE8"XX"150A	VENTILATION PLATE (BOTTOM)	*
E	RE800057	VENTILATION HUB	ALL
F	RE800214	BACK VENTILATION CHANNEL	ALL

*MODEL SPECIFIC

Description

COOKING CHAMBER & VENT



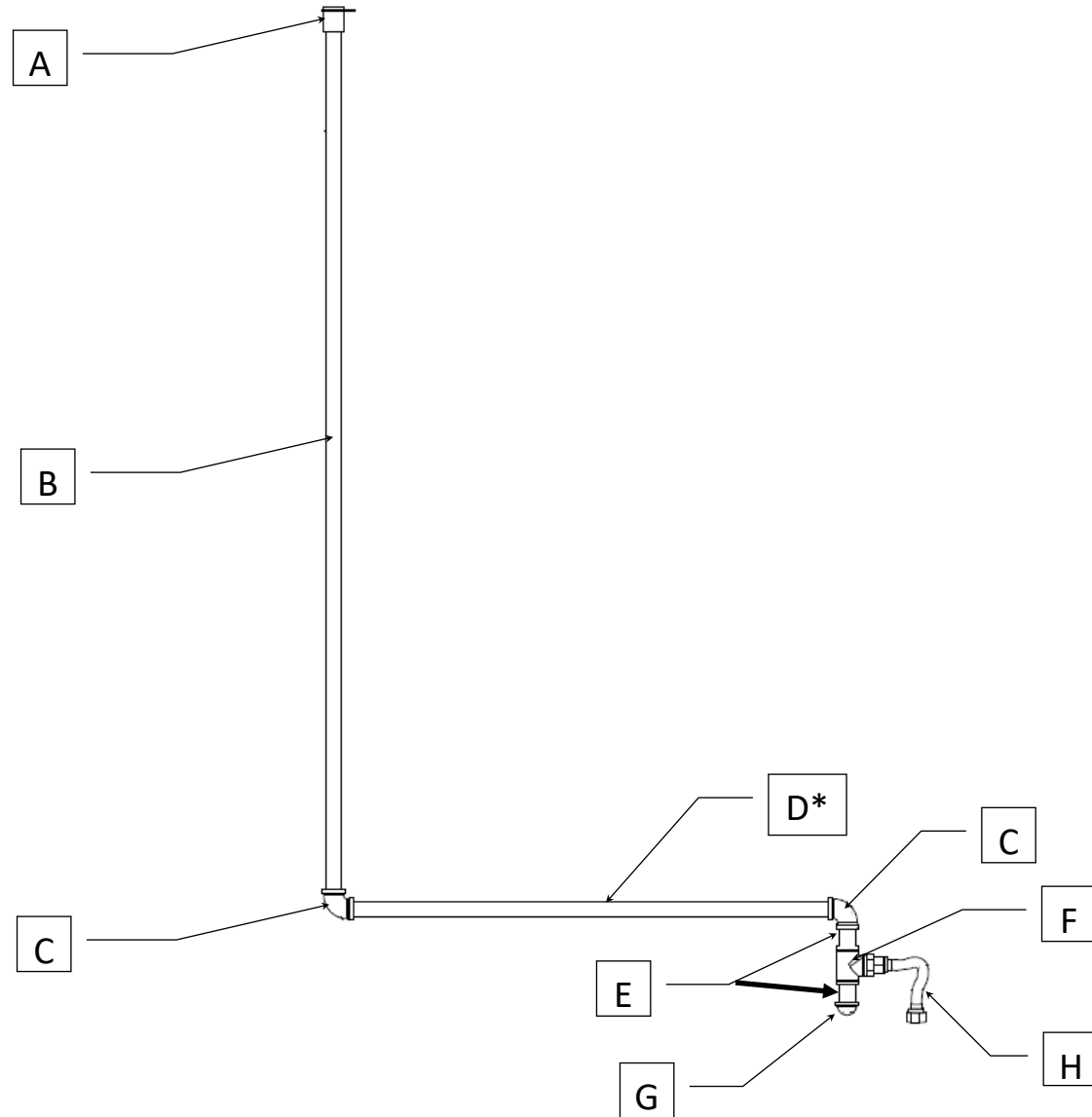

#	Part #	Description	Model
A	RE800077	GAS LINE SUPPORT	ALL
B	RE800302	VERTICAL GAS PIPE	ALL
C	PL29-0025	ELBOW	ALL
D	RE8"XX"304	HORIZONTAL GAS PIPE	*
E	PL29-0021	BLACK IRON NIPPLE 3/4" x 2"	ALL
F	PL29-0023	" T " FITTING 3/4" BLACK IRON	ALL
G	PL29-0032	CAP 3/4"	ALL
H	PL29-0123	FLEXIBLE HOSE & FITTING	ALL

*MODEL SPECIFIC

Description

GAS LINE



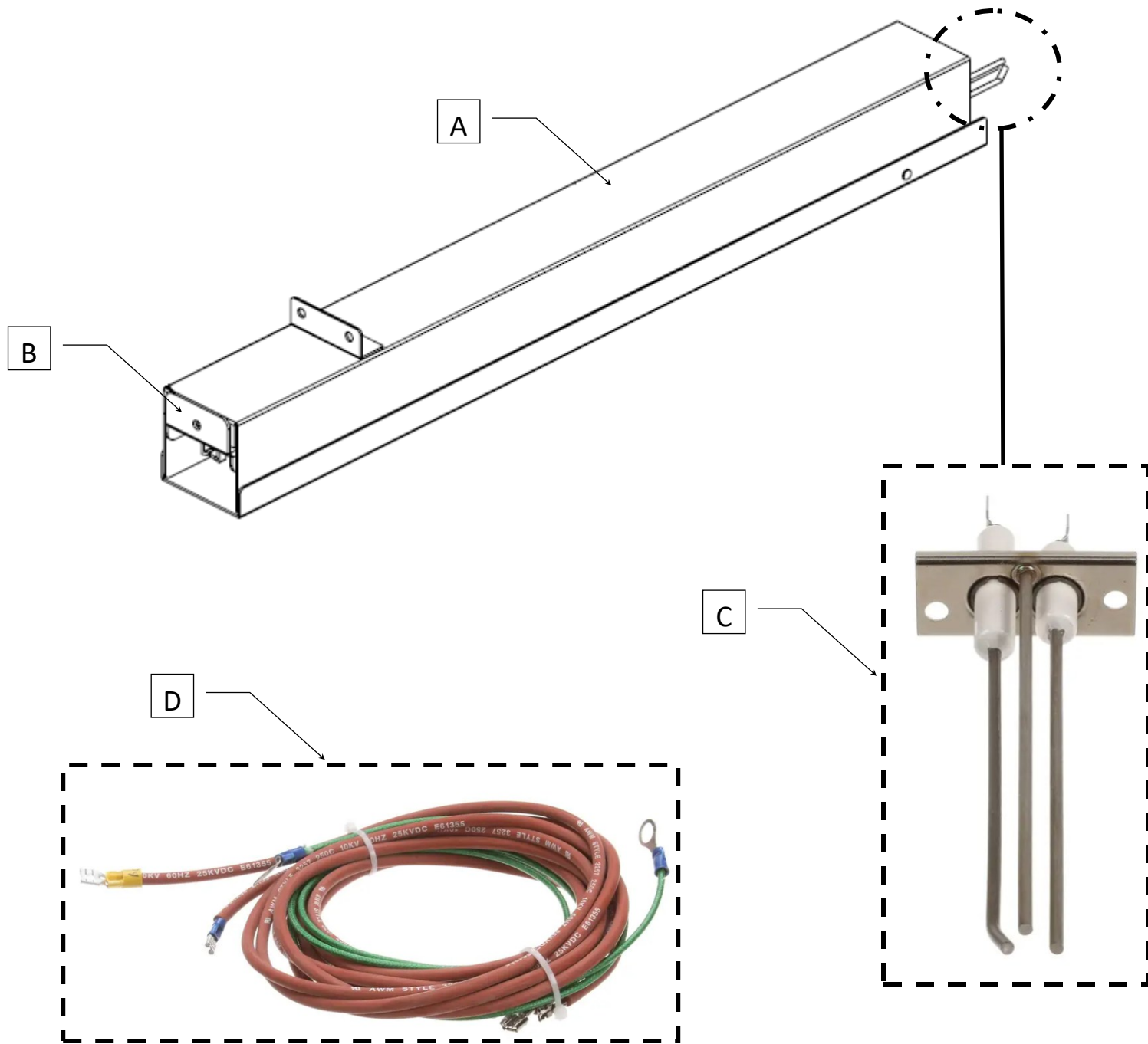

#	Part #	Description	Model
A	RE800549	IGNITION SUPPORT TUBE	ALL
B	RE800561	IGNITOR SUPPORT BRACKET	ALL
C	PL69-0016	IGNITION ROD AND SENSOR ASSEMBLY	ALL
D	RE8"XX"603	IGNITION CABLES	*

*MODEL SPECIFIC

Description

IGNITION ASSEMBLY CHANNEL



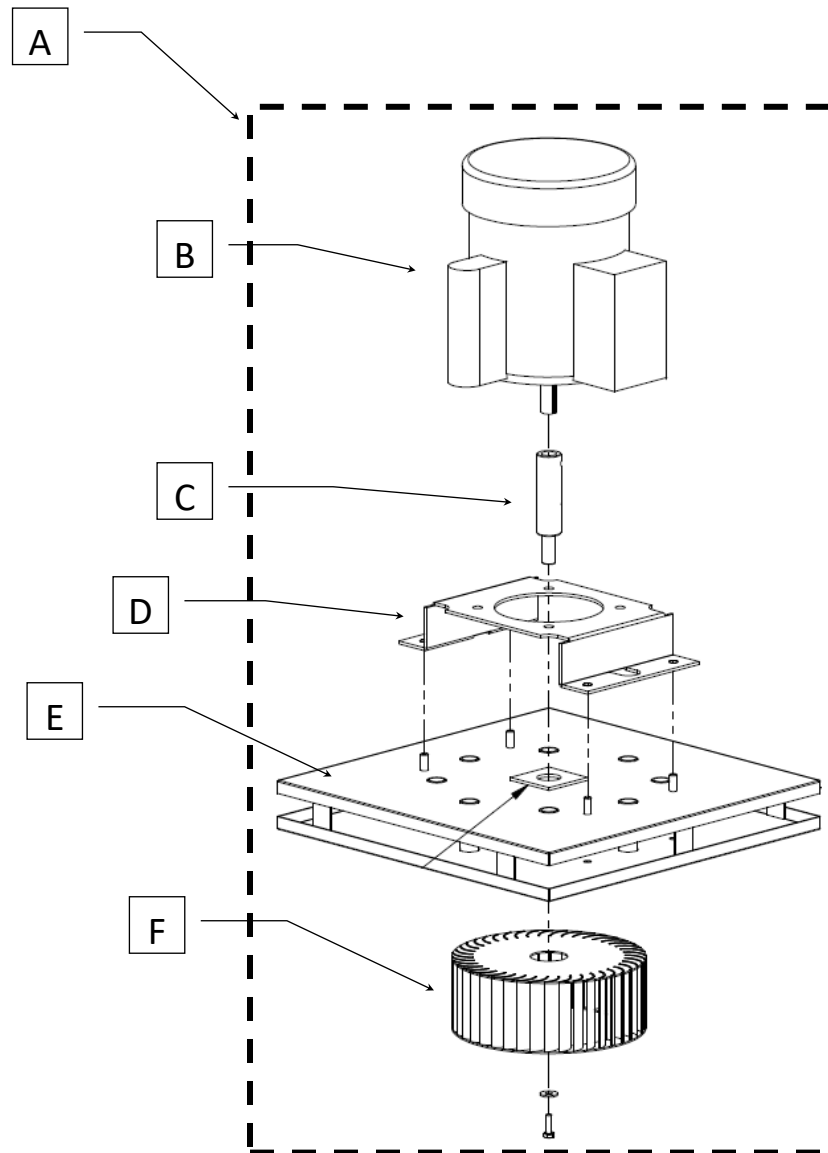

#	Part #	Description	Model
A	RE800025	VENTILATION MOTOR ASSEMBLY	ALL
B	EL32-0090	MOTOR 1/3 HP 1800 RPM 115 / 208-230V 60HZ 1PH WITH C FLANGE	ALL
C	RE800435	MOTOR SHAFT EXTENSION	ALL
D	RE800182	FAN MOTOR SUPPORT	ALL
E	RE800042	VENTILATION COVER	ALL
F	VE68-0004	BLOWER WHEEL	ALL

*MODEL SPECIFIC

Description

FAN MOTOR ASSEMBLY



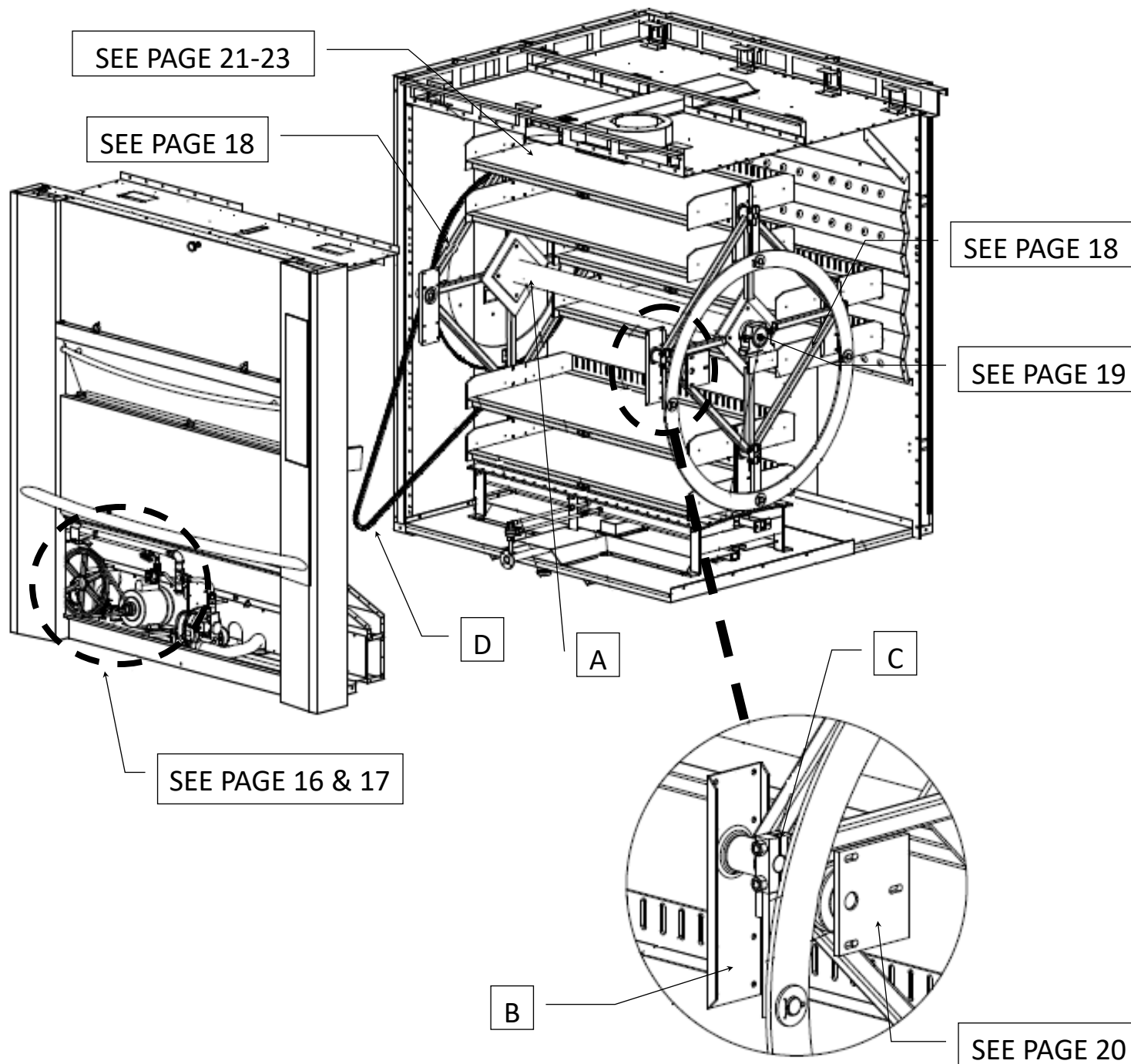

#	Part #	Description	Model
A	RE8"XX'045	CENTER SHAFT	*
B*	RE800045D	RIGHT SHELVES SUPPORT (8 shelves config)	RE-8-XX
B*	RE800045G	LEFT SHELVES SUPPORT (8 shelves config)	RE-8-XX
B*	RE800045D-4	RIGHT SHELVES SUPPORT (4 shelves config)	RE-4-XX
B*	RE800045G-4	LEFT SHELVES SUPPORT (4 shelves config)	RE-4-XX
C	RE800060	STABILIZING ARM	ALL
D	ME61-0037	CHAIN	ALL

*MODEL SPECIFIC

Description

MECHANIC



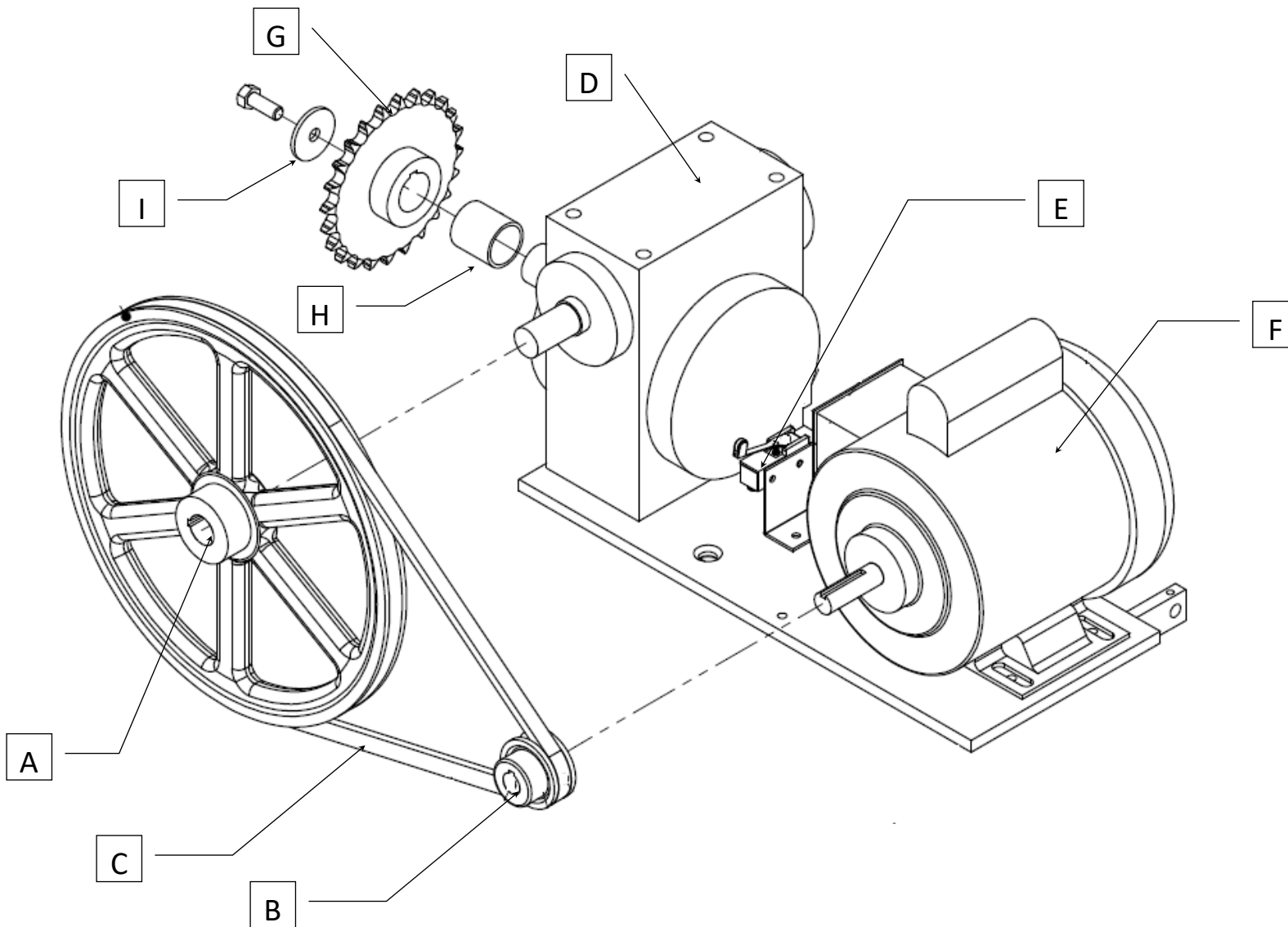

#	Part #	Description	Model
A	ME19-0001	PULLEY MA120 x 7/8 "	ALL
B	ME19-0034	PULLEY MA30 x 5/8 "	ALL
C	ME27-0063	V BELT	ALL
D	ME26-0007	GEARBOX	ALL
E	EL66-0017	LIMIT SWITCH	ALL
F	EL32-0001	MOTOR 1/2 HP 1725 RPM 115/230V 60Hz 1 PH	ALL
G	ME57-0081	SPROCKET #50, TYPE B, 24 TEETH, 1 1/8"	ALL
H	RE800332B	SPROCKET SPACER	ALL
I	RE800332A	SPROCKET SPACING WASHER	ALL

*MODEL SPECIFIC

Description

MECHANIC—60 SECONDS GEARBOX ASSEMBLY



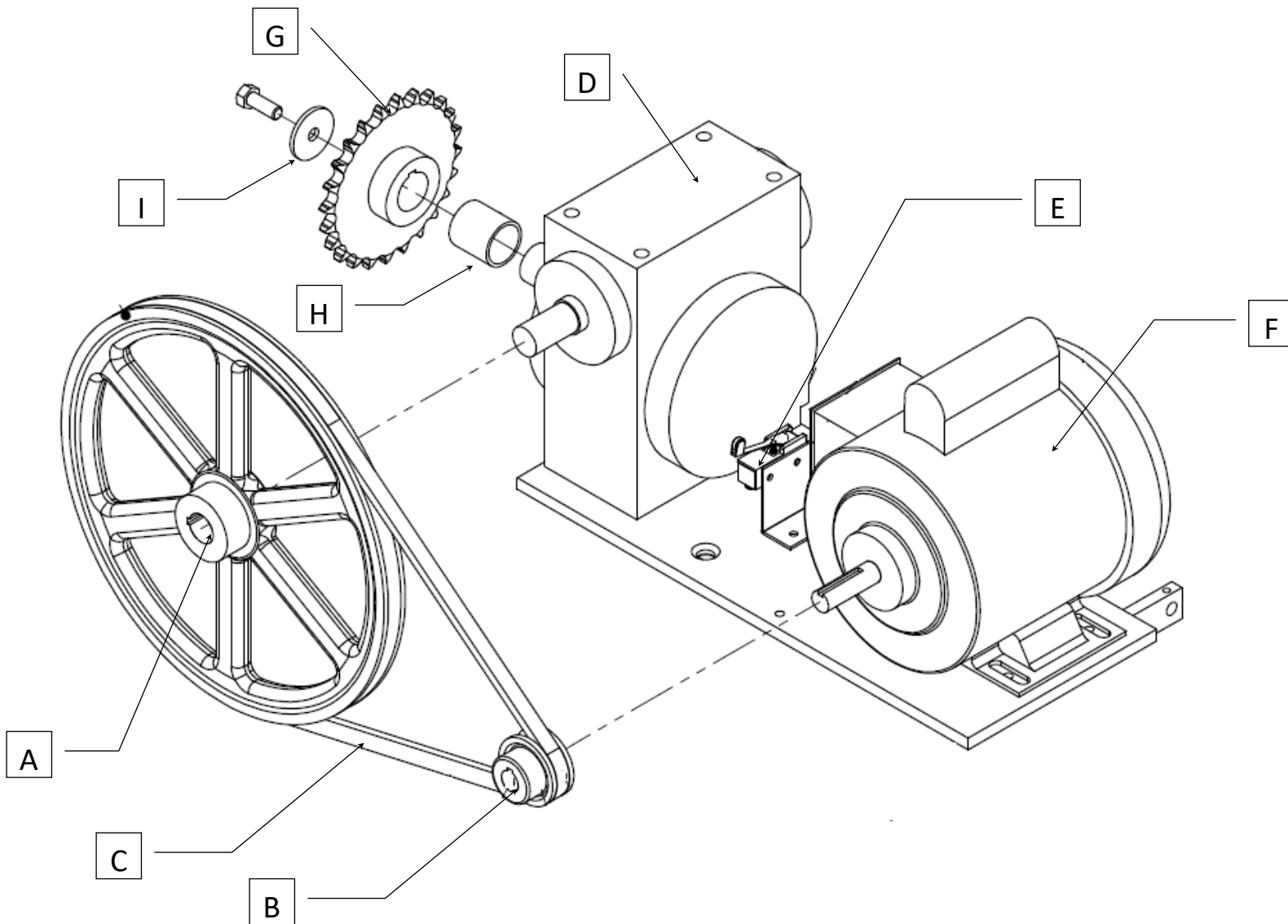

#	Part #	Description	Model
A	ME19-0001	PULLEY MA120 x 7/8 "	ALL
B	ME19-0002	PULLEY MA20 x 5/8"	ALL
C	ME27-0023	V BELT	ALL
D	ME26-0007	GEARBOX	ALL
E	EL66-0017	LIMIT SWITCH	ALL
F	EL32-0001	MOTOR 1/2 HP 1725 RPM 115/230V 60Hz 1 PH	ALL
G	ME57-0081	SPROCKET #50, TYPE B, 24 TEETH, 1 1/8"	ALL
H	RE800332B	SPROCKET SPACER	ALL
I	RE800332A	SPROCKET SPACING WASHER	ALL

*MODEL SPECIFIC

Description

MECHANIC 90 SECONDS GEARBOX ASSEMBLY



LEFT SIDE OF THE UNIT

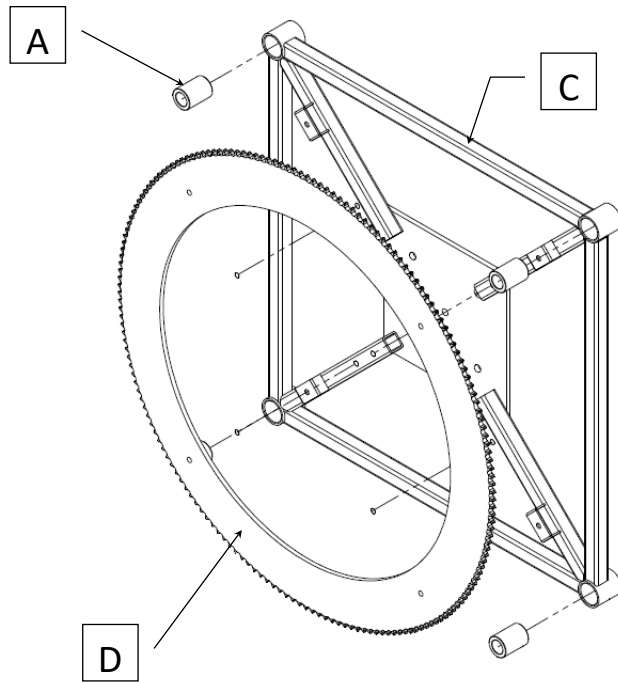

RIGHT SIDE OF THE UNIT

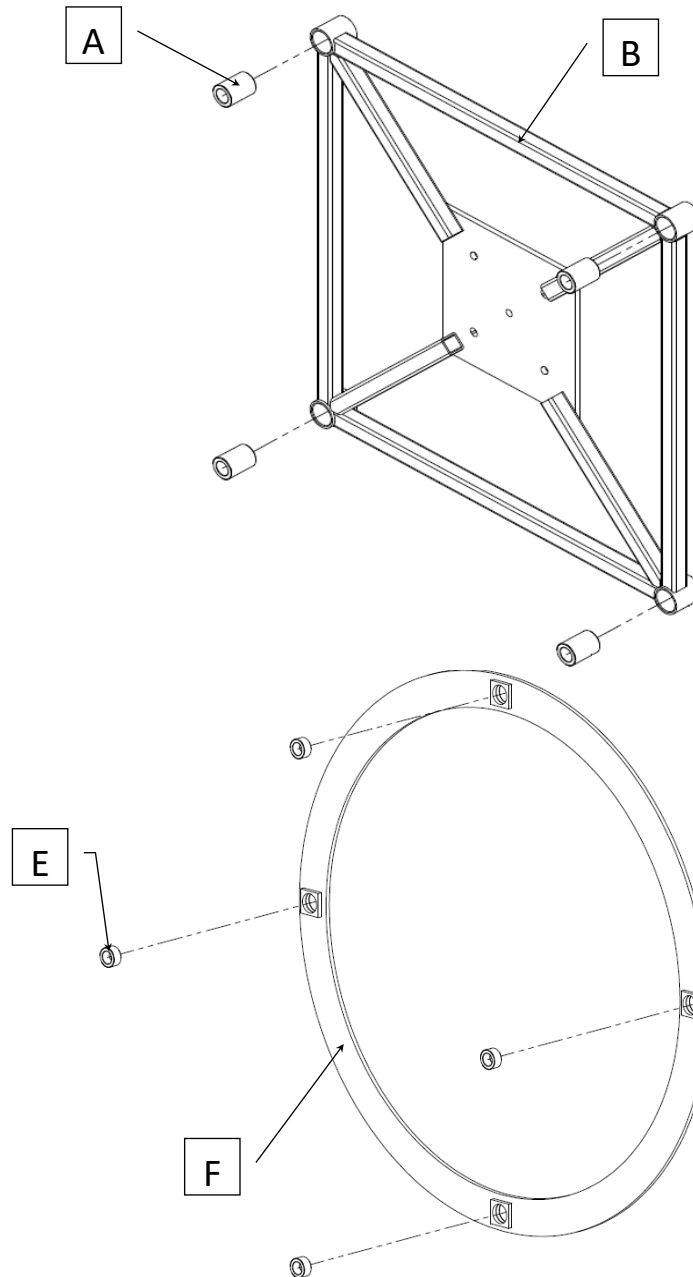

#	Part #	Description	Model
A	RE800405	ROTATING SUPPORT BUSHING	ALL
B	RE800040D	RIGHT ROTATING SUPPORT	ALL
C	RE800040G	LEFT ROTATING SUPPORT	ALL
D	RE800564	SPROCKET #50	ALL
E	RE800409	STABILIZING WHEEL BUSHING	ALL
F	RE800043	STABILIZING WHEEL	ALL

*MODEL SPECIFIC

Description

MECHANIC



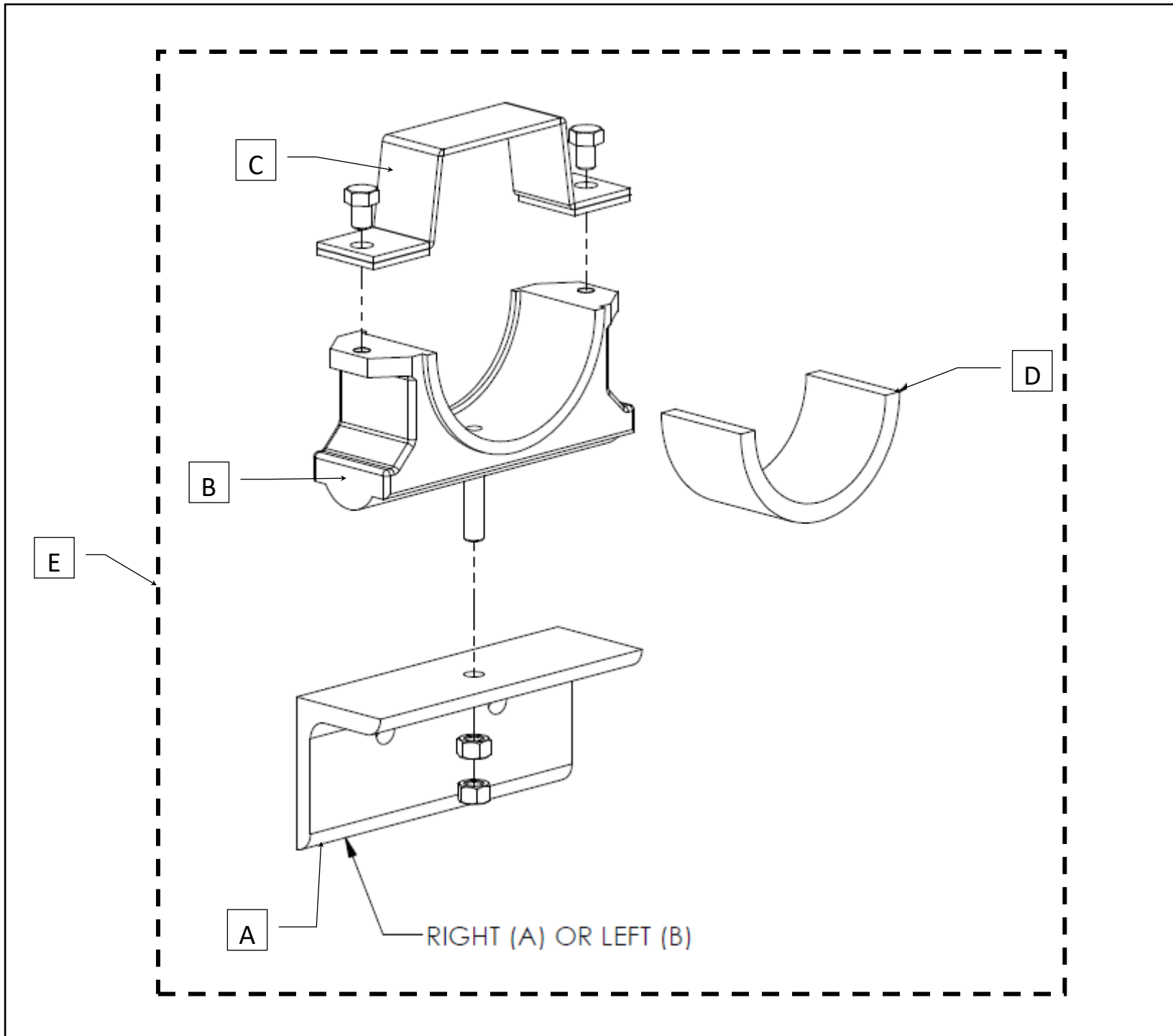

#	Part #	Description	Model
A	RE800322-A or RE800322-B	PILLOW BLOCK SUPPORT	ALL
B	RE800411M	PILLOW BLOCK	ALL
C	RE800089	PILLOW BLOCK COVER	ALL
D	RE800413	PILLOW BLOCK BUSHING	ALL
E	RE800047A OR RE800047B	PILLOW BLOCK ASSEMBLY	ALL

*MODEL SPECIFIC

Description

MECHANIC



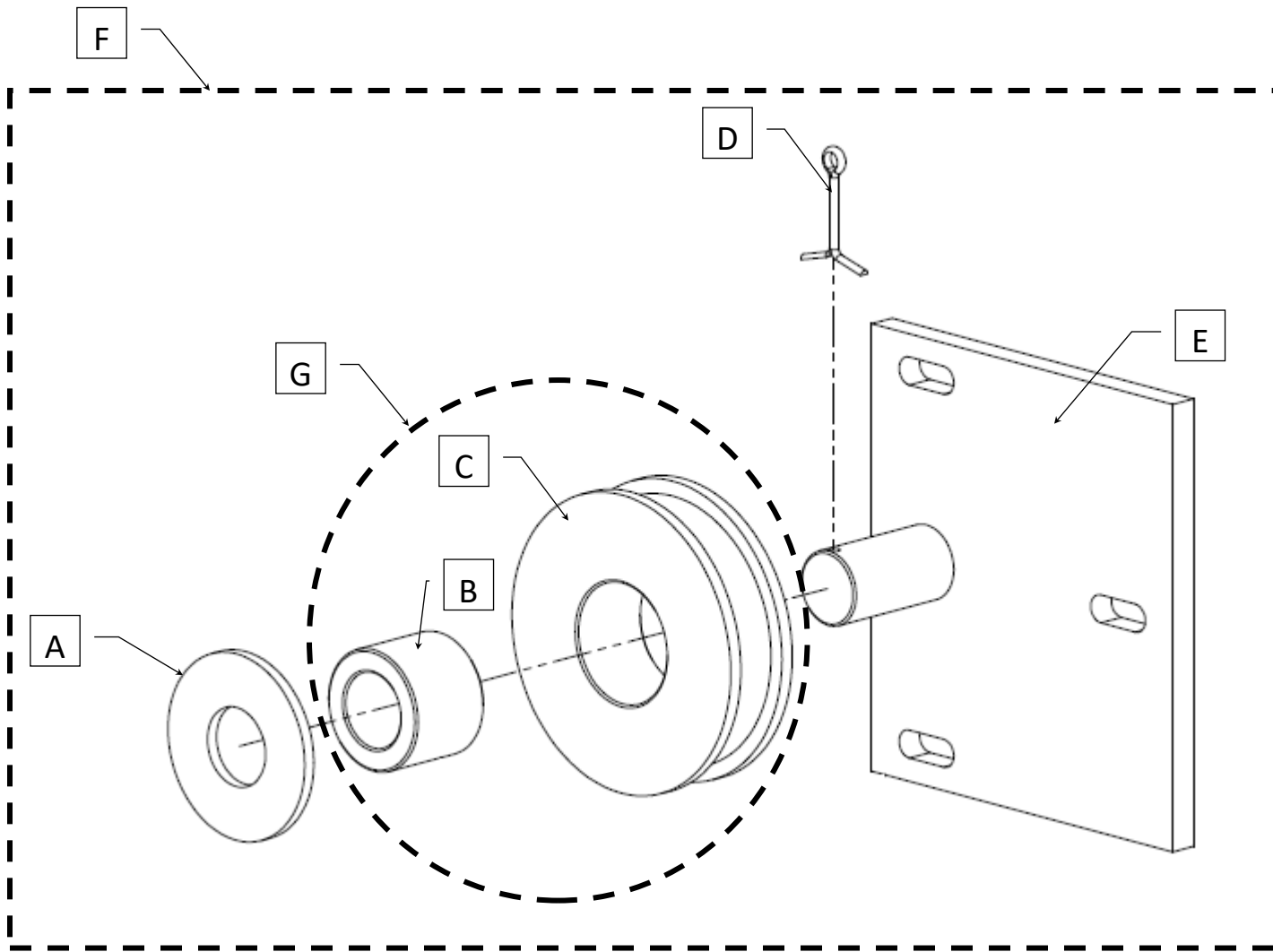

#	Part #	Description	Model
A	QU28-0287	FLAT WASHER 1"	ALL
B	RE800416	BUSHING STABILIZER WHEEL	ALL
C	RE800417	SMALL STABILIZING WHEEL	ALL
D	QU28-0076	COTTER PIN 1/8" x 2"	ALL
E	RE800049	SMALL STABILIZING WHEEL SUPPORT	ALL
F	RE800050	SMALL STABILIZING WHEEL ASSEMBLY	ALL
G	RE800417A	STABILIZATION WHEEL AND BUSHING ASSEMBLY	ALL

*MODEL SPECIFIC

Description

MECHANIC



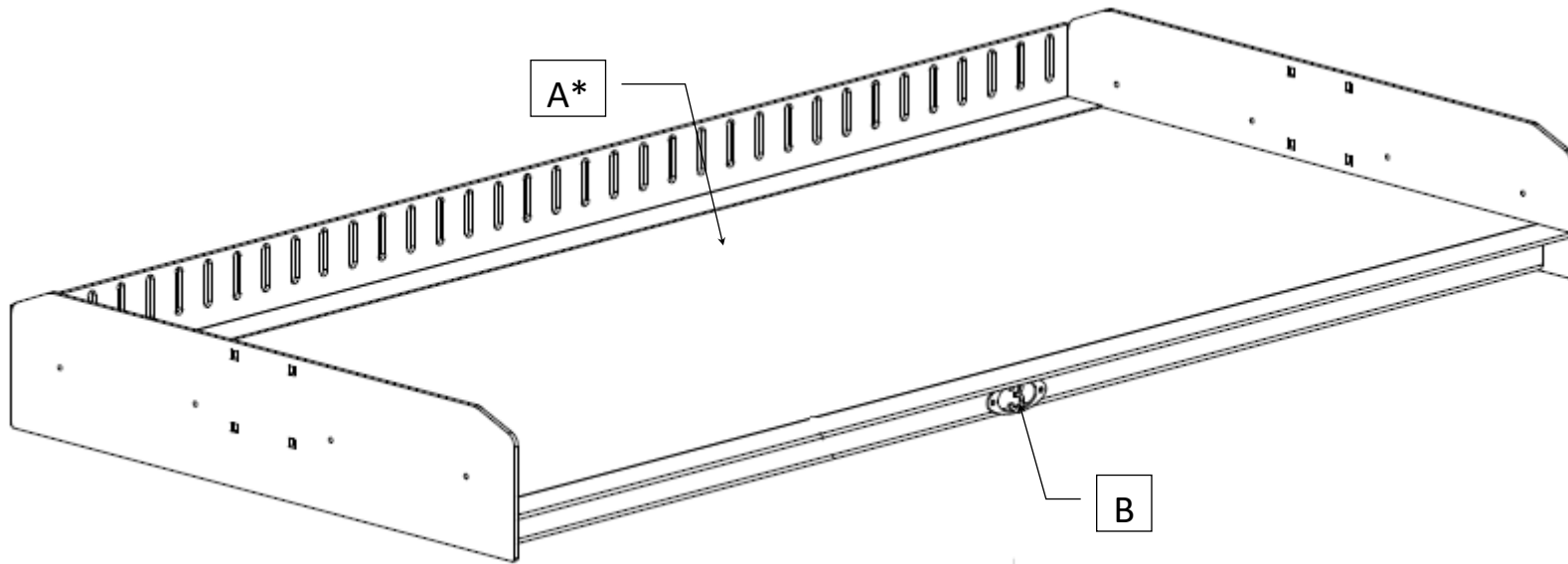

#	Part #	Description	Model
A*	RE8"XX"046A	FULL STEEL SHELVES ASSEMBLY	*
B	RE800252-X X = 1-8	NUMBER PLATE	*

*MODEL SPECIFIC

Description

SHELF-FULL STEEL



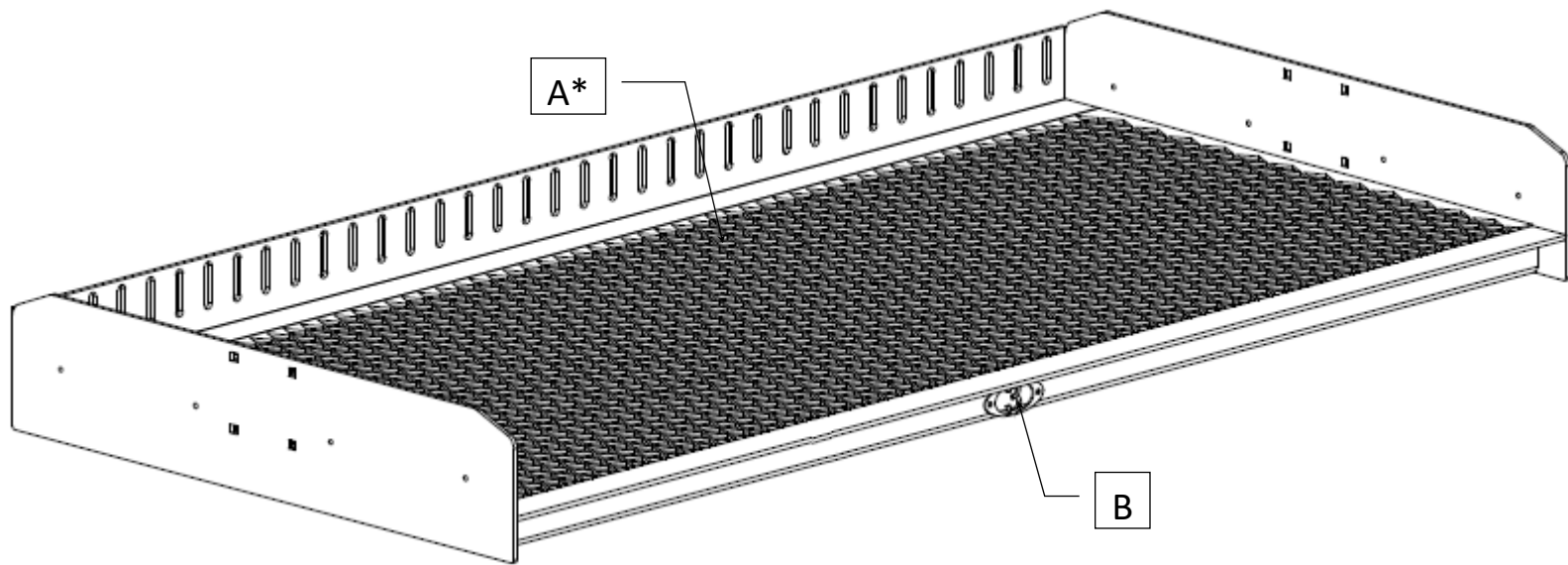

#	Part #	Description	Model
A*	RE8"XX"046B	PERFORATED STEEL SHELVES ASSEMBLY	*
B	RE800252-X X = 1-8	NUMBER PLATE	*

*MODEL SPECIFIC

Description

SHELF-PERFORATED STEEL



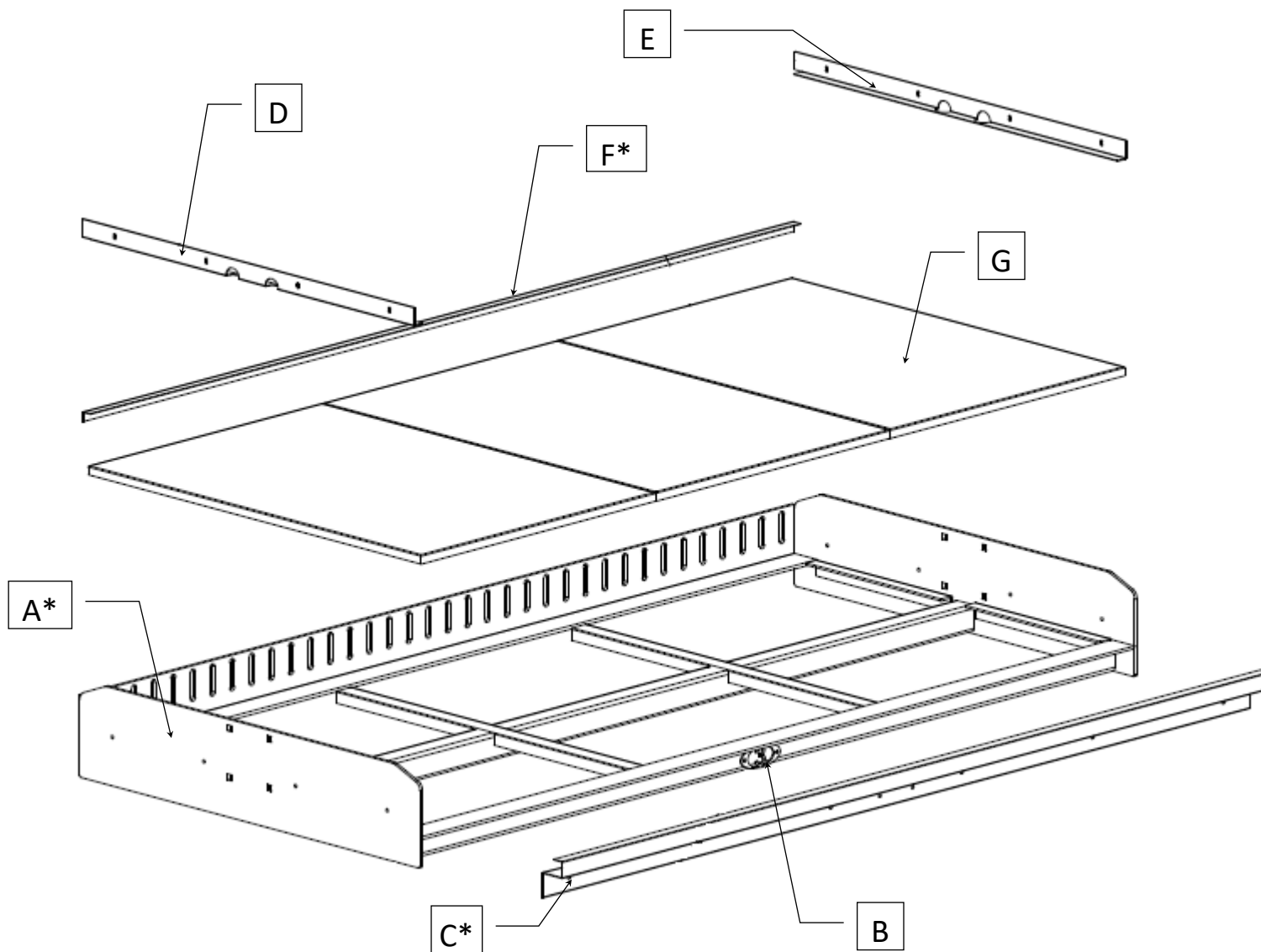

#	Part #	Description	Model
A*	RE8"XX"046C	STONE SHELVES ASSEMBLY	*
B	RE800252-X X = 1-8	NUMBER PLATE	*
C	RE8"XX"147A	SHELVE'S FRONT PLATE	*
D	RE800217B	LEFT SIDE EDGE BRACKET	ALL
E	RE800217A	RIGHT SIDE EDGE BRACKET	ALL
F	RE8"XX"148	STONE GUARD	*
G	ME84-0001	BAKING STONE 1/2" x 17 7/8" x 25 3/4"	ALL

*MODEL SPECIFIC

Description

SHELF-STONE



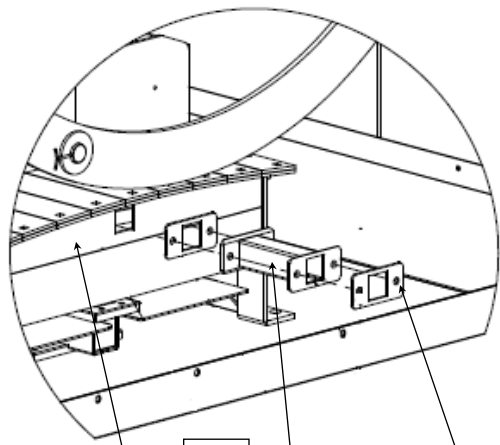

VIEW A A* B* C

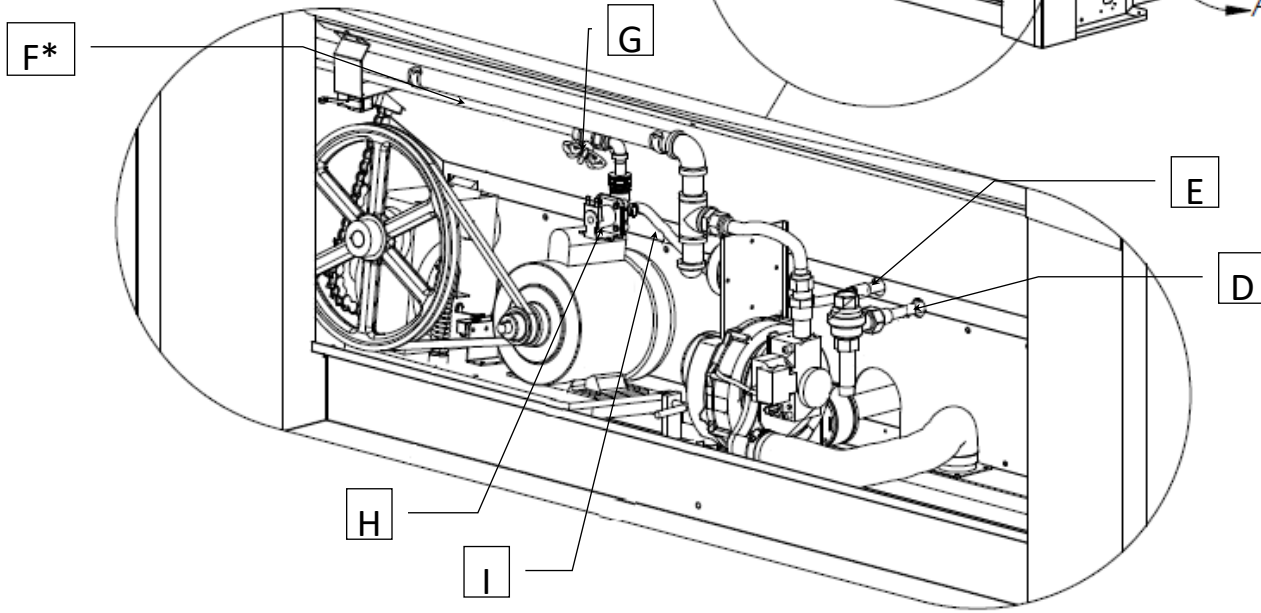
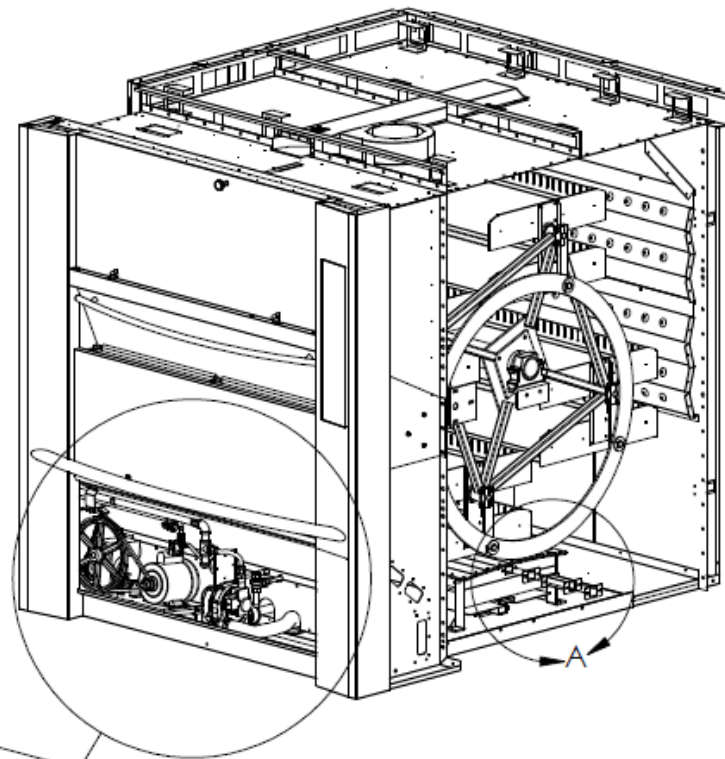

#	Part #	Description	Model
A	RE8"XX"039	STEAM PLATE	*
B	RE8"XX"088	STEAM PIPE ATTACH	*
C	RE800436	STEAM PIPE JOINT	ALL
D	RE800065	WATER OUTLET	ALL
E	RE800066	WATER RETURN	ALL
F	RE8"XX"058	WATER INLET	*
G	PL07-0009	GATE VALVE 1/4 NPT	ALL
H	PL07-0050	SOLENOID VALVE 24V/60 1/4 NPT	ALL
I	RE800450	WATER HOSE	ALL

*MODEL SPECIFIC

Description

MECHANIC

