

Model LP-280

## All Aluminum Construction Picard's Bowl Lift

For Hobart Bowls



**Picard's bowl lift allows for safe lifting and tilting of bowls.**

One person can move, raise and tilt a full 140-quart bowl without effort. Designed for your own safety and that of your employees. Do not risk injuries by handling heavy loads.



**PICARD**

BAKERY EQUIPMENT INC.

# Picard bowl lift for Hobart bowls, model LP-280



## Features

- Aluminum construction for sanitary and weight purposes.
- The telescopic post, in resting position, can pass through a regular doorframe (34" x 80").
- Two safety devices: safety snap hooks and locking mechanism on the tilting device.
- Safe hydraulic power system.
- Mobile, hand-held control box.
- If mobility is essential: Rechargeable 12-volt battery. Long lasting: it can lift 50 to 60 times before reloading. Built-in battery charger. Charge indicator lets you know when to recharge. (Model LP-280-B)
- If mobility is not essential: Model without battery using direct 110-volt power, 5 amperes. (Model LP-280)
- Load capacity: 400 pounds.
- Maximum dumping height: 76" (60-quart bowl), 74" (80-quart bowl) and 72" (140-quart bowl).
- Will fit 60, 80 and 140-quart Hobart bowls.
- Simple manual adjustment to change bowl size.
- A person alone can use the lift.
- Mounted on solid 5-inch wheels.

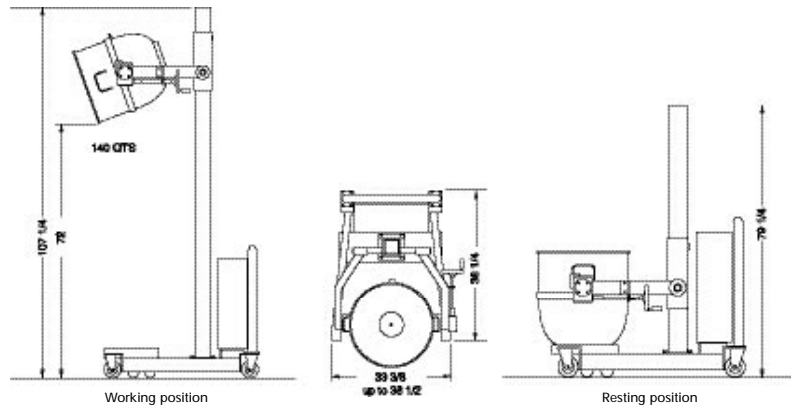

## How to use the bowl lift in 8 easy steps.

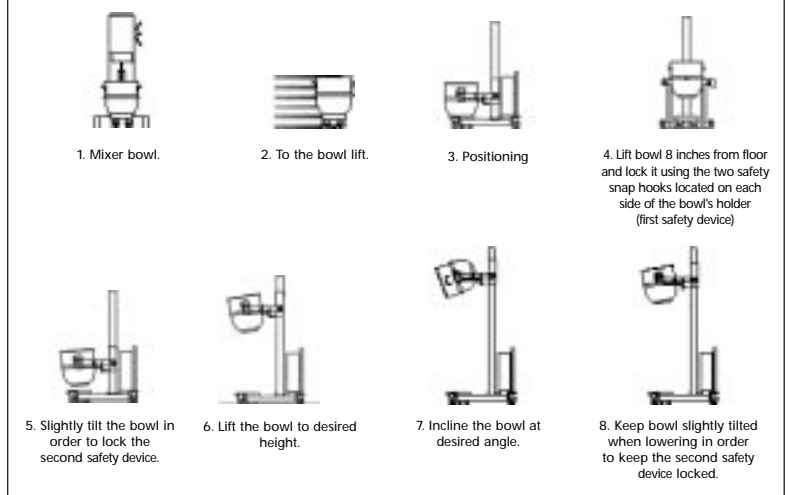

Your Authorized Dealer:

