

REVOLUTION ELECTRIC FIRED OVEN

Standard Features

- Electric Oven
- Stainless steel exterior walls (side 1 & facade), galvanized steel (side 2 & back) and aluminized steel walls/roof
- Panoramic window above the loading door
- Aluminum counter-balanced door
- Digital control
- Loading door with 10" high opening
- Numbered solid steel or expanded metal shelves with 3" back riser
- 1 fluorescent light outside the oven
- Front access doors to driving system and electrical components
- Exhaust Hood (Type II)
- Available with 8, 12, 16, 20, 24 or 32 pan capacity

Options

- Exhaust Hood (Type I) with grease trap
- Baking stone shelves (½" thickness)
- Full stainless steel exterior walls
- Stainless steel floor plate and main shaft
- Self-generating steam system



Model

- RE-4-8 (8 pans 18" x 26")
- RE-4-12 (12 pans 18" x 26")
- RE-4-16 (16 pans 18" x 26")
- RE-8-16 (16 pans 18" x 26")
- RE-8-24 (24 pans 18" x 26")
- RE-8-32 (32 pans 18" x 26")

Installation

A Picard Ovens approved technician will take care of the unloading and installation at the customer's site. All oven parts can pass through a regular 36" x 80" door and can be moved by hand.

All electrical, water, and chimney hook-ups, along with the oven start-up, are at the customer's expense and have to be performed by a qualified installation technician and according to local codes.



REVOLUTION OVEN - ELECTRIC FIRED

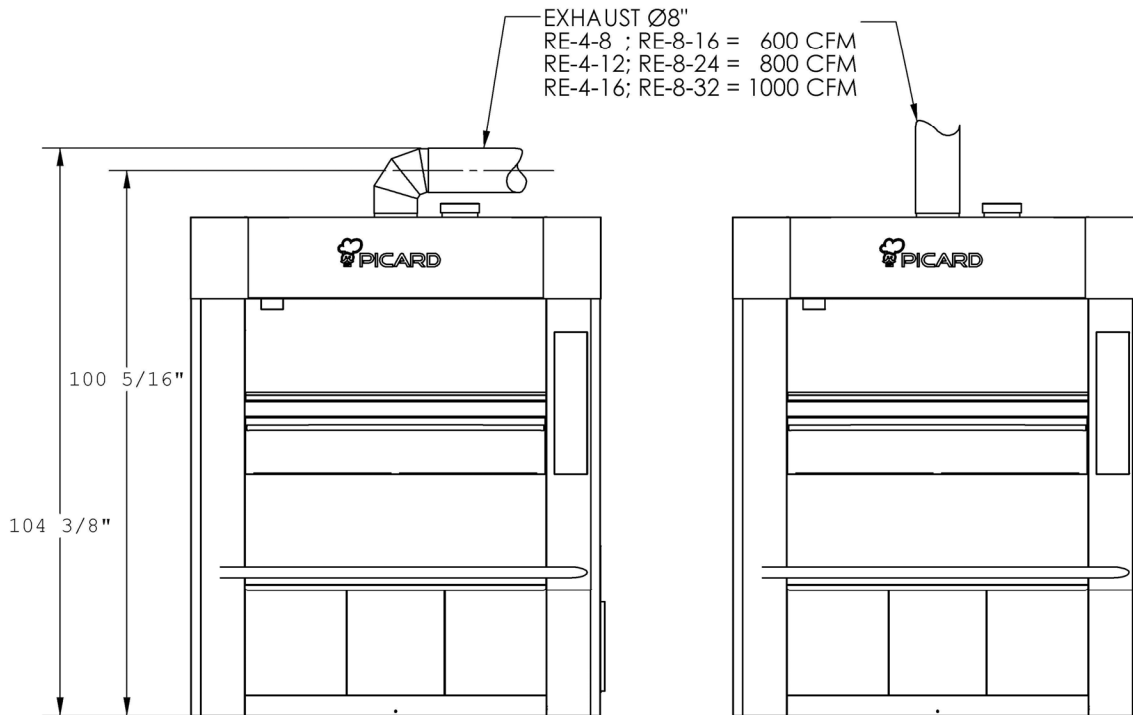
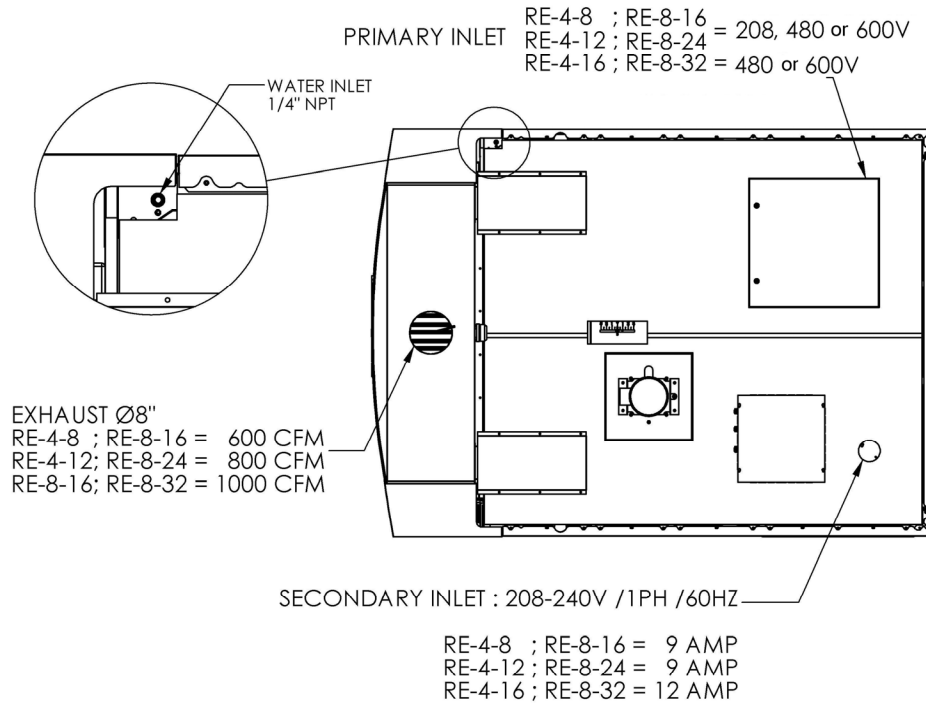

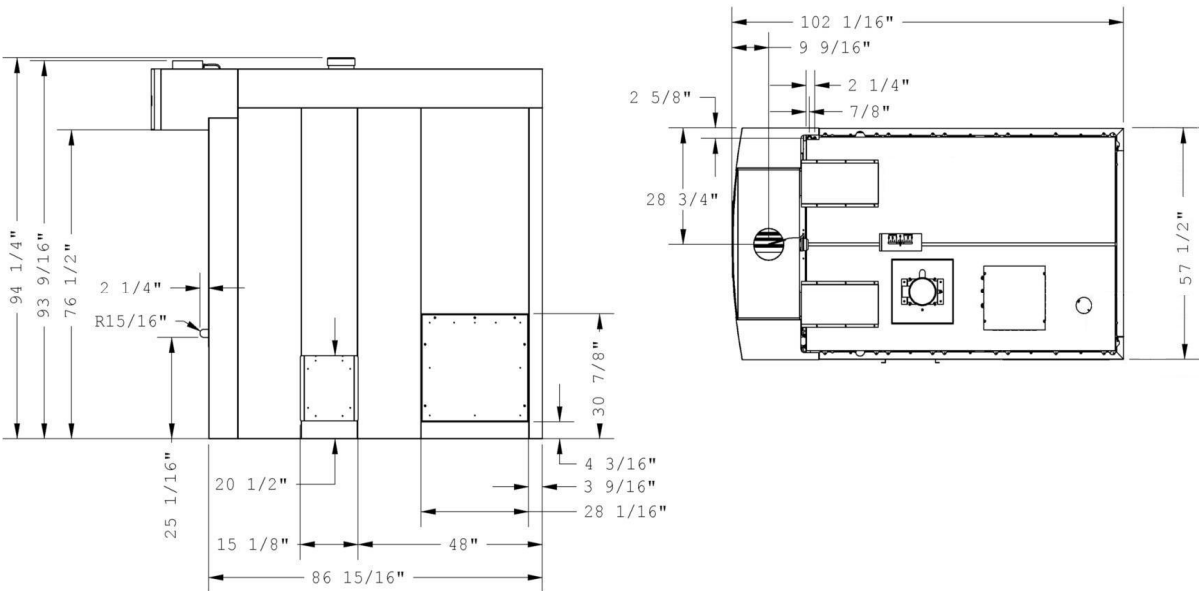
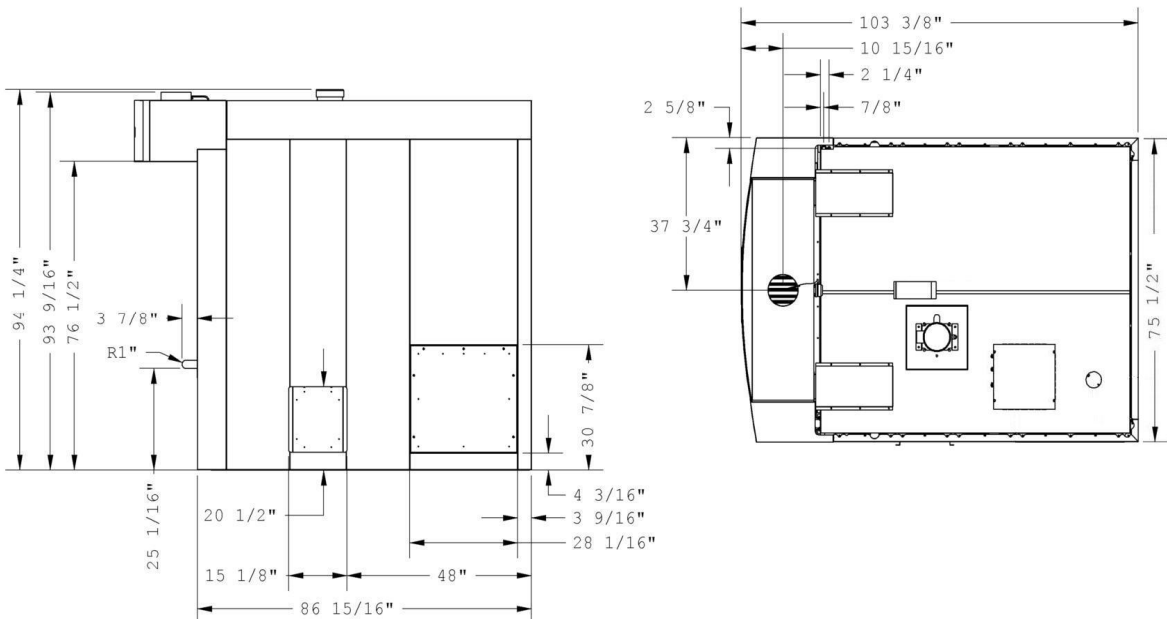
RE-8-16

RE-8-24

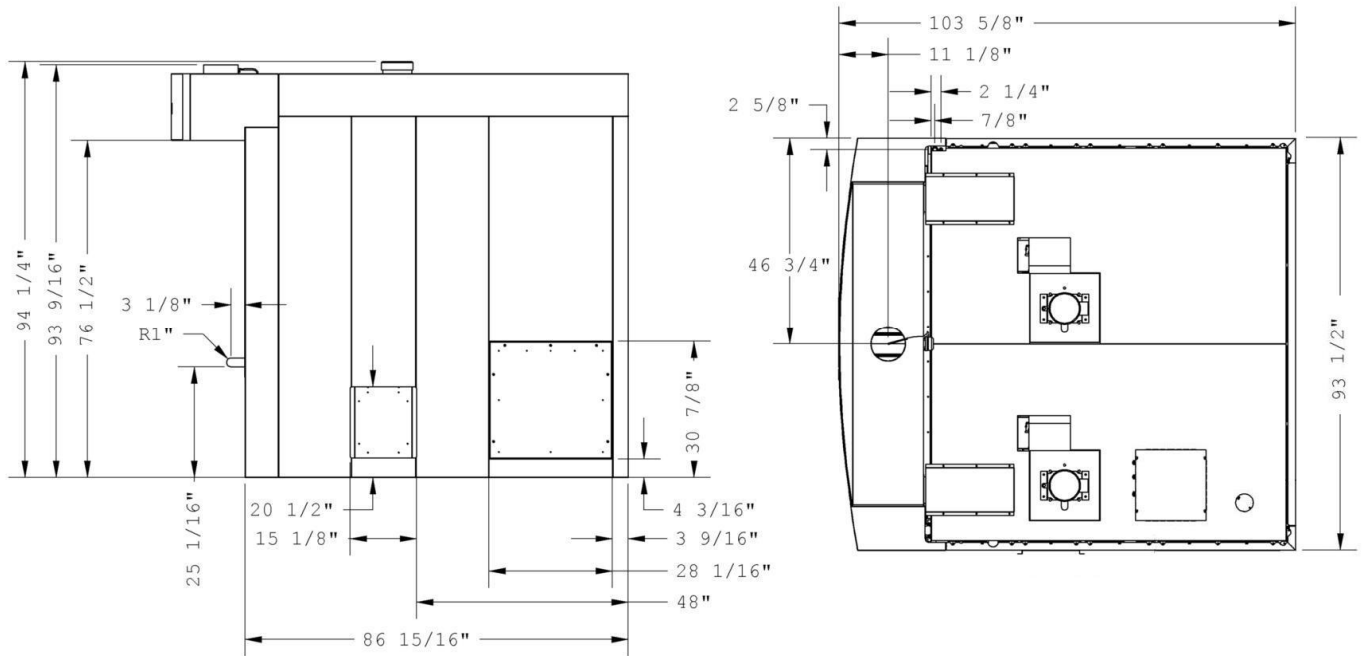
RE-8-32





► RECOMMENDED MINIMAL CLEARANCE

Floor to ceiling	Side and back to wall	Floor	Manhole side
98"	1"	Approved for non-combustible surface	24"

► SHIPMENT INFORMATION

Model	Ship weight	Crate dimensions			Model	Ship weight	Crate dimensions
RE-4-8	2 500 lbs	64"	92"	88"	RE-8-16	2 800 lbs	64"
RE-4-12	3 000 lbs	83"	92"	88"	RE-8-24	3 300 lbs	83"
RE-4-16	4 300 lbs	90"	120"	88"	RE-8-32	4 300 lbs	90"

► ELECTRICAL RATING

MODEL	VOLT	AMPERE	KW	SECONDARY CONNECTION
RE-4-8	208V/3PH/60HZ	109 A	36 KW	NONE
	480V/3PH/60HZ	43 A		208V/1PH/60HZ/9A
	600V/3PH/60HZ	36 A		208V/1PH/60HZ/9A
RE-4-12	208V/3PH/60HZ	134 A	45 KW	NONE
	480V/3PH/60HZ	54 A		208V/1PH/60HZ/9A
	600V/3PH/60HZ	45 A		208V/1PH/60HZ/9A
RE-4-16	-	-	54 KW	-
	480V/3PH/60HZ	65 A		208V/1PH/60HZ/11A
	600V/3PH/60HZ	54 A		208V/1PH/60HZ/11A
RE-8-16	208V/3PH/60HZ	109 A	36 KW	NONE
	480V/3PH/60HZ	43 A		208V/1PH/60HZ/9A
	600V/3PH/60HZ	36 A		208V/1PH/60HZ/9A
RE-8-24	208V/3PH/60HZ	134 A	45 KW	NONE
	480V/3PH/60HZ	54 A		208V/1PH/60HZ/9A
	600V/3PH/60HZ	45 A		208V/1PH/60HZ/9A
RE-8-32	-	-	54 KW	-
	480V/3PH/60HZ	65 A		208V/1PH/60HZ/11A
	600V/3PH/60HZ	54 A		208V/1PH/60HZ/11A

► BAKING CAPACITIES

Trays			Bagels	Breads			Pies	Pizzas					
Model	Qty	Size	5 oz	Pans (18" x 26")	1 lb	1.5 lb	9"	8"	10"	12"	14"	16"	18"
RE-4-8	4	26" X 36 ½"	120	8	60	48	36	44	24	16	12	8	8
RE-4-12	4	26" X 54 ½"	180	12	80	64	56	64	32	32	16	12	12
RE-4-16	4	26" X 72 ½"	240	16	120	96	72	88	48	32	24	16	16
RE-8-16	8	26" X 36 ½"	240	16	120	96	72	88	48	32	24	16	16
RE-8-24	8	26" X 54 ½"	360	24	160	128	112	128	64	64	32	24	24
RE-8-32	8	26" X 72 ½"	480	32	240	192	144	176	96	64	48	32	32

* Continuous product development is a Picard policy. Therefore, we reserve the right to change specifications and/or design without prior notice.