

Revolution Revolving Tray Oven

Gas Fired

Standard Features

- Natural or propane gas
- Stainless steel exterior walls (side 1 & facade), galvanized steel (side 2 & back) and aluminized steel interior walls/roof
- Panoramic window above the loading door
- Aluminum counter-balanced door
- Digital control
- Loading door with 10" high opening
- Numbered solid steel or expanded metal shelves with 3" back risers
- 1 neon light outside the oven window
- Front access doors to driving system, gas and electrical components
- Available with 8, 12, 16, 24 or 32 pan capacity
- Exhaust canopy (Type II)

Options

- Exhaust canopy (Type I) with grease trap
- Baking stone shelves (1/2" thickness)
- Self-generating steam system
- Full stainless steel exterior walls
- Stainless steel floor and main shaft

Models

- RE-4- 8 (8-pan)
- RE-4-12 (12-pan)
- RE-4-16 (16-pan)
- RE-8-16 (16-pan)
- RE-8-24 (24-pan)
- RE-8-32 (32-pan)

Installation

A Picard Ovens approved technician will take care of the unloading and installation at the customer's site.

All oven parts can pass through a regular 36" x 80" door and can be moved by hand.

All electrical, gas, water, and chimney hook-ups, along with the oven burner's start-up, are at the customer's expense and have to be done by the qualified installation technician and according to local codes.



Revolution Revolving Tray Oven Gas Fired

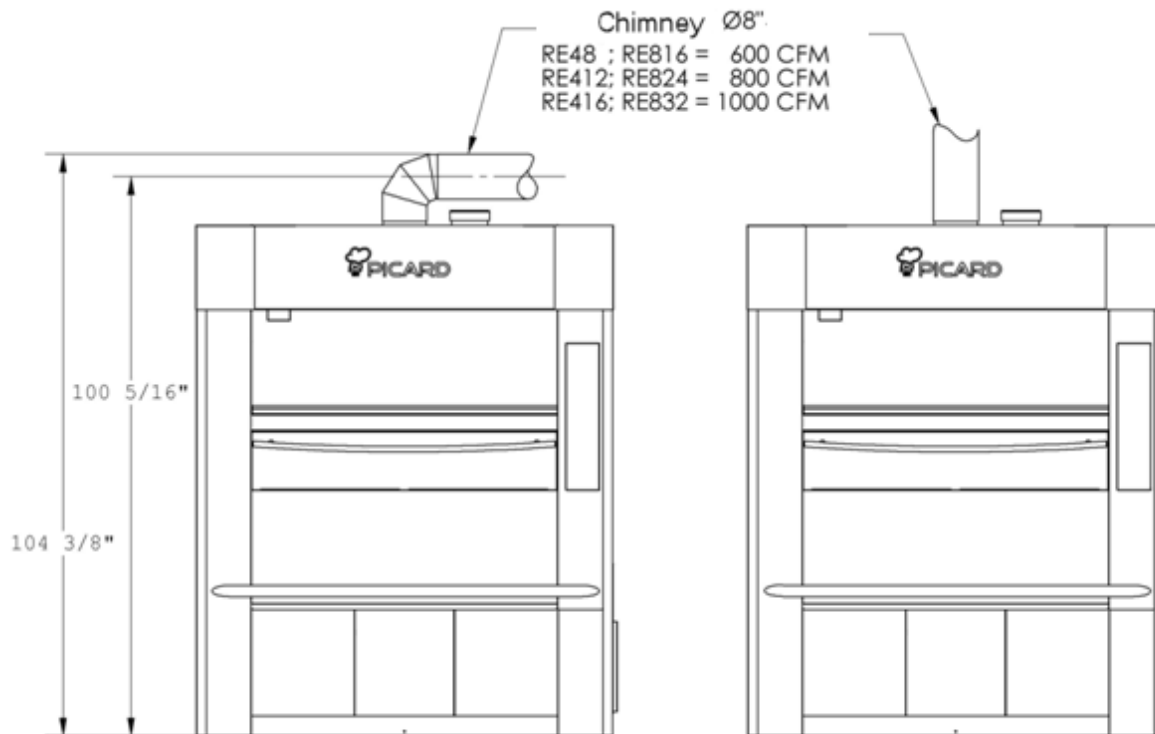
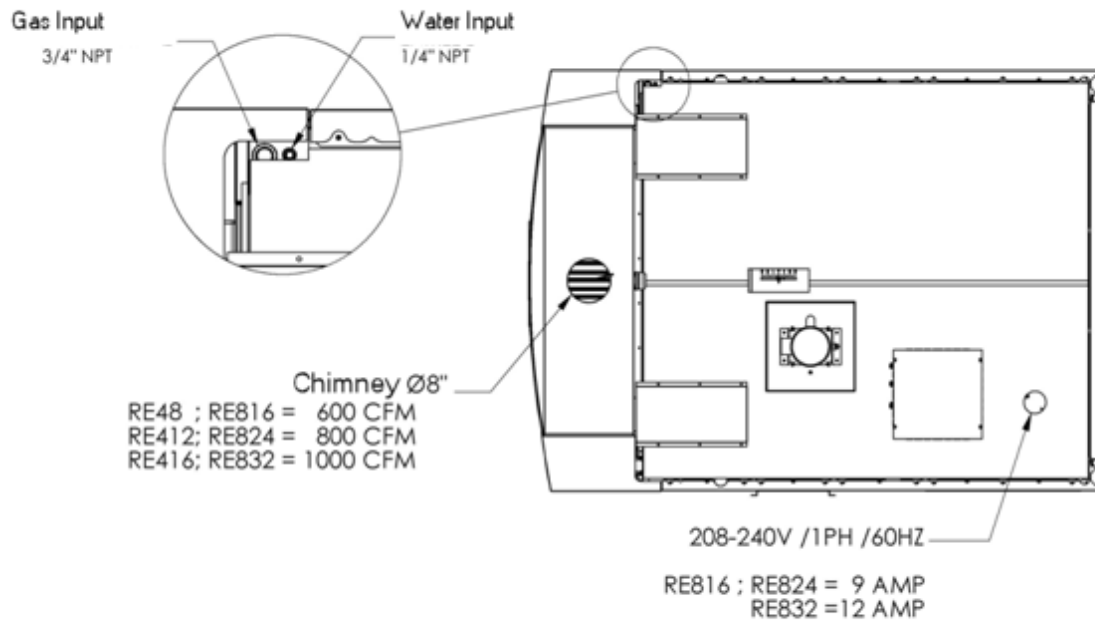

RE-8-16

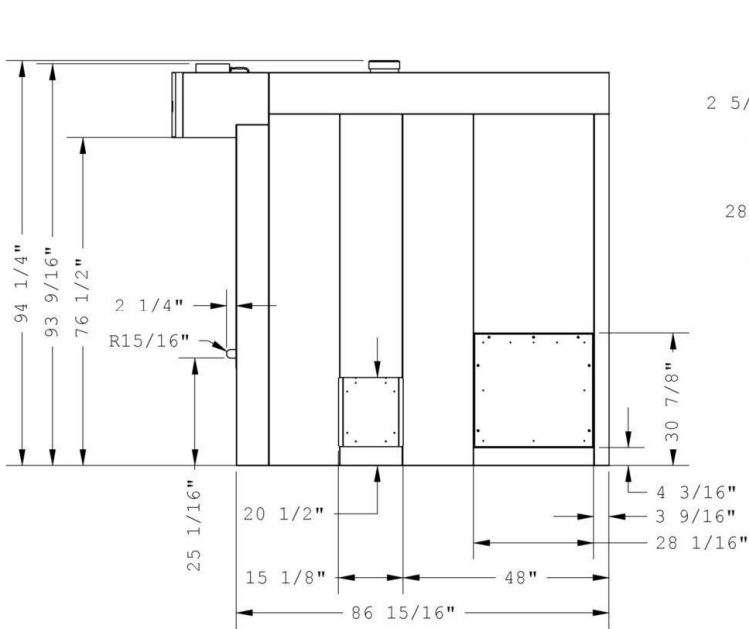

RE-8-24

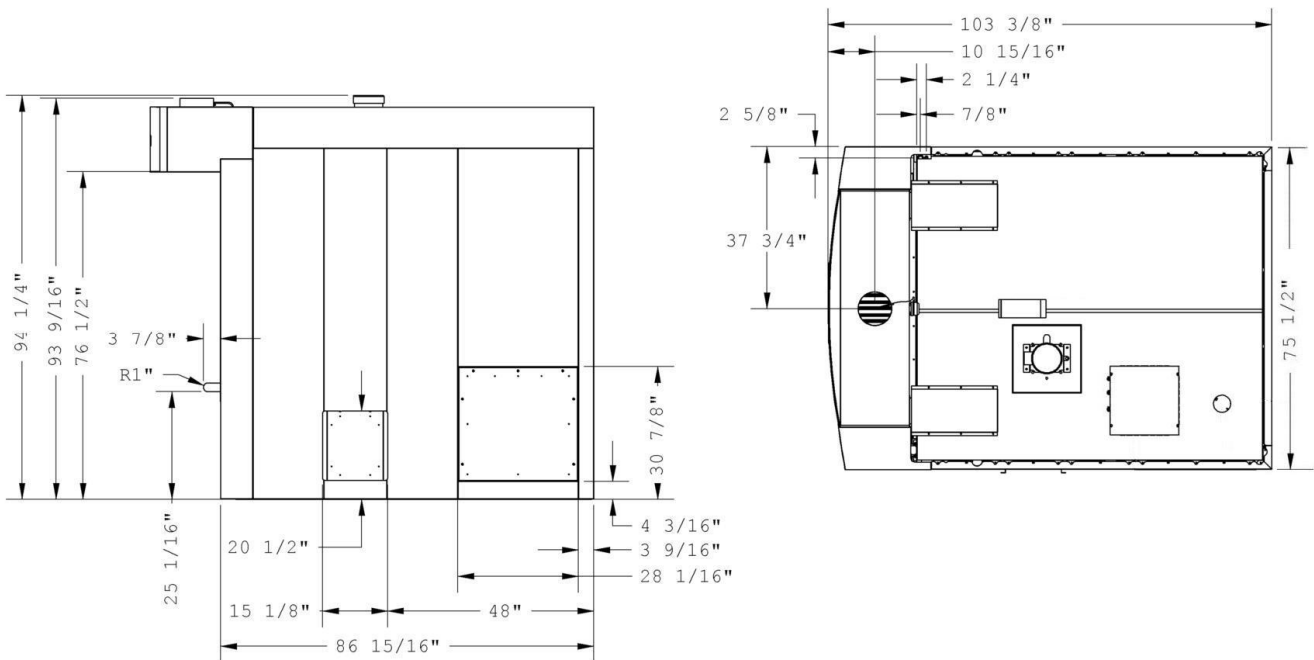

RE-8-32

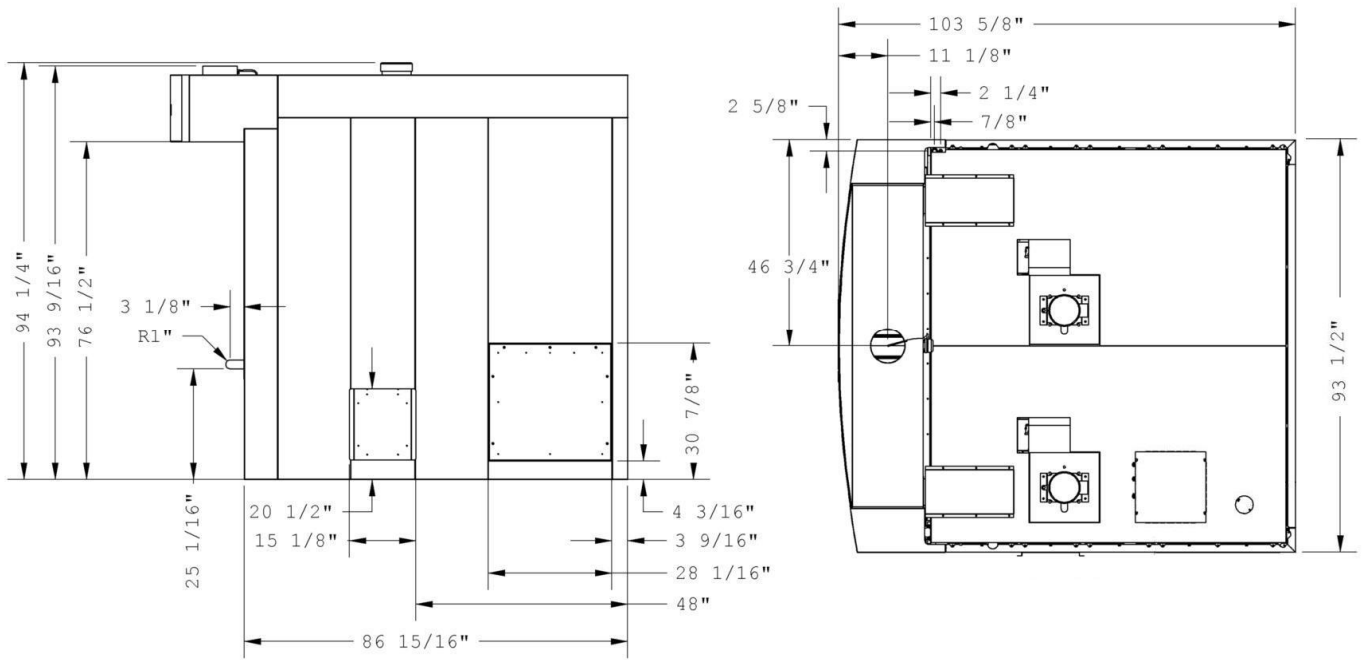



Picard Ovens, Inc.

►RECOMMENDED MINIMUM CLEARANCES

Floor to ceiling	Side and back to wall	Floor	Manhole side
98"	1" for burner air intake	Approved for non-combustible surfaces	24"

►GAS SUPPLY SPECIFICATIONS

TYPE	Min. Gas Pipe Size	Line pressure	Power (BTU/HR)					
			RE 4-8	RE 4-12	RE 4-16	RE 8-16	RE 8-24	RE 8-32
Natural Gas	3/4" NPT	5"-14" W.C.	150 000	200 000	250 000	150 000	200 000	250 000
Propane Gas	3/4" NPT	5"-14" W.C.	150 000	200 000	250 000	150 000	200 000	250 000

►ELECTRICAL RATING

Model	Voltage	Phase	Hertz	Amps	Supply
RE-4-8	208-240V	1	60	9	3 wires including ground
RE-4-12				9	
RE-4-16				9	
RE-8-16				9	
RE-8-24				12	
RE-8-32				12	

►SHIPPING DIMENSIONS

Model	Ship Weight (1)	Crate dimensions		
		64"	92"	88"
RE-4-8	2 500 lbs	64"	92"	88"
RE-4-12	3 000 lbs	83"	92"	88"
RE-4-16	3 800 lbs	90"	100"	88"
RE-8-16	2 800 lbs	64"	92"	88"
RE-8-24	3 300 lbs	83"	92"	88"
RE-8-32	4 300 lbs	90"	100"	88"

►BAKING CAPACITY

Model	Trays		Bagels	Breads			Pies	Pizzas					
	Qty	Size	5 oz	Pans (18" x 26")	1 lb	1.5 lb	9"	8"	10"	12"	14"	16"	18"
RE-4-8	4	26" X 36 ½"	120	8	60	48	36	44	24	16	12	8	8
RE-4-12	4	26" X 54 ½"	180	12	90	72	54	66	36	24	18	12	12
RE-4-16	4	26" X 72 ½"	240	16	120	96	72	88	48	32	24	16	16
RE-8-16	8	26" X 36 ½"	240	16	120	96	72	88	48	32	24	16	16
RE-8-24	8	26" X 54 ½"	360	24	180	144	108	132	72	48	36	24	24
RE-8-32	8	26" X 72 ½"	480	32	240	192	144	176	96	64	48	32	32

* Continuous product development is a Picard policy. Therefore, we reserve the right to change specifications and/or design without prior notice.