

The Oven
Revolution
hybrid

IGNITE THE FUTURE



Revolutionary
Benefits





Advantages



Compact size



Versatile



Self generating steam



Economical



Low maintenance



Advantages

Compact size

The Revolution oven's compact size is only one of the many ways that this oven is revolutionizing the history of revolving ovens. The Revolution oven boasts one of the smallest footprints available on the market in its category.

Versatile

The Revolution oven is a continuous baking type oven with direct fired radiant heat and not a convection type oven. Many different products may be baked at the same time enabling you to increase your sales, baking everything your customers could ever want, when they want it.

Self generating steam

One major advantage of the Revolution oven is its self generating steam system. It permits you to produce high quality artisan bread. If you wish, you can bake directly on stone shelves; you will obtain flavorful, quality products while using a Revolution hybrid.

Economical

Because this oven takes up less of your kitchen space and offers an ergonomic design so you can double up on quantity. This added to an extremely efficient burner system helps you economize on multiple levels, reducing your operating cost.

Low maintenance

Picard has become famous for providing some of the industry's most innovative and durable ovens. We continue this long tradition by making the Revolution simple to clean, impervious to rust and trouble-free to operate. Count on your Revolution to provide you with years of hassle-free service.

IGNITE THE FUTURE



General Information



The newly designed Revolution is a piece of art in itself. Sleek european design suggests high technology coupled with unadulterated clean lines.

The Revolution oven is a rotating oven that is revolutionizing the history of revolving ovens.

It has a large capacity with a state of the art burner that uses between 150,000 to 250,000 BTU, depending on the oven size, even while using steam! It has one of the smallest footprints in the industry, 43 Sq Ft (24 pan model). Because its thermal insulation is so effective, it can be installed at 0 clearance against combustible surfaces from the side, back and floor. It can even be installed on a wooden floor. The Revolution has access panels that enable cleaning the interior of the oven with a vacuum from the exterior of the oven.

Versatility is what it's all about today and this oven gives you just that. Models are available for natural gas, propane or electric.



The Revolution Line-Up

Models	Shelves	Pans
Revolution 8)	4	8
Revolution 12)	4	12
Revolution 16)*	4	16
Revolution 16)	8	16
Revolution 24)	8	24
Revolution 32)*	8	32

* Gas models only

The Oven **Revolution** hybrid

Combines the best qualities of all types of ovens.
Let us introduce you to just a few;

- | We have succeeded in compressing 50% of the volume of a regular revolving tray oven.
- | We integrated a self generating steam system unique in the revolving tray oven business.
- | In comparison to other ovens, energy cost can be cut close to in half, especially when adding a steam system to the oven.
- | Now we would like to introduce you to a Picard exclusive. We have added a gentle air circulation system, AeroMax, to insure our client's perfect success. Contrary to convection ovens, the AeroMax system gently directs air through orifices located on the interior front and back walls of the baking chamber. This method permits faster and equal baking. The system is factory adjusted but permits a customized adjustment at the clients local if desired.
- | Last but not the least, we present you with PowerMax, our new state of the art burner system. This burner system has a direct flame burner with exceptional flame stability. This burner's flame lowers and rises adjusting to the required temperature but doesn't go out until you choose it to. The burner maintains constant temperature, with a powerful maximum energy output. The PowerMax system burns clean, silent and is maintenance free.

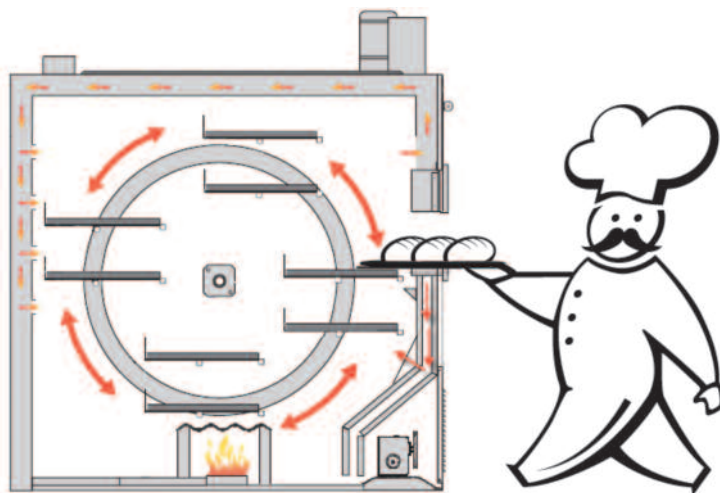

INTERNAL VENTILATION SYSTEM



**What makes
the Revolution
oven a hybrid?**

The Revolution Characteristics

The Revolution has a large panoramic window with a full length fluorescent lamp to illuminate the baking chamber. It comes with numbered, full or expanded steel shelves or with optional baking stone shelves. Integrated into this oven is a type II ventilation canopy (type I optional) and a quick steam evacuation pull knob for a perfect control.

The Revolution also has a well thought out digital control panel, the Feather-touch control pad.

The control pad fits the needs of the busiest bakery with the same european type style. Easy to visually locate and use settings while wearing a mitten. A pre-set recipe area also allows for one touch operation. No need for an expert operator to run this oven.

All your thoughts about rack ovens and the pioneer revolving ovens are about to change in one quick look. The beauty of this oven speaks volumes of delivering an elegant savoir-faire.

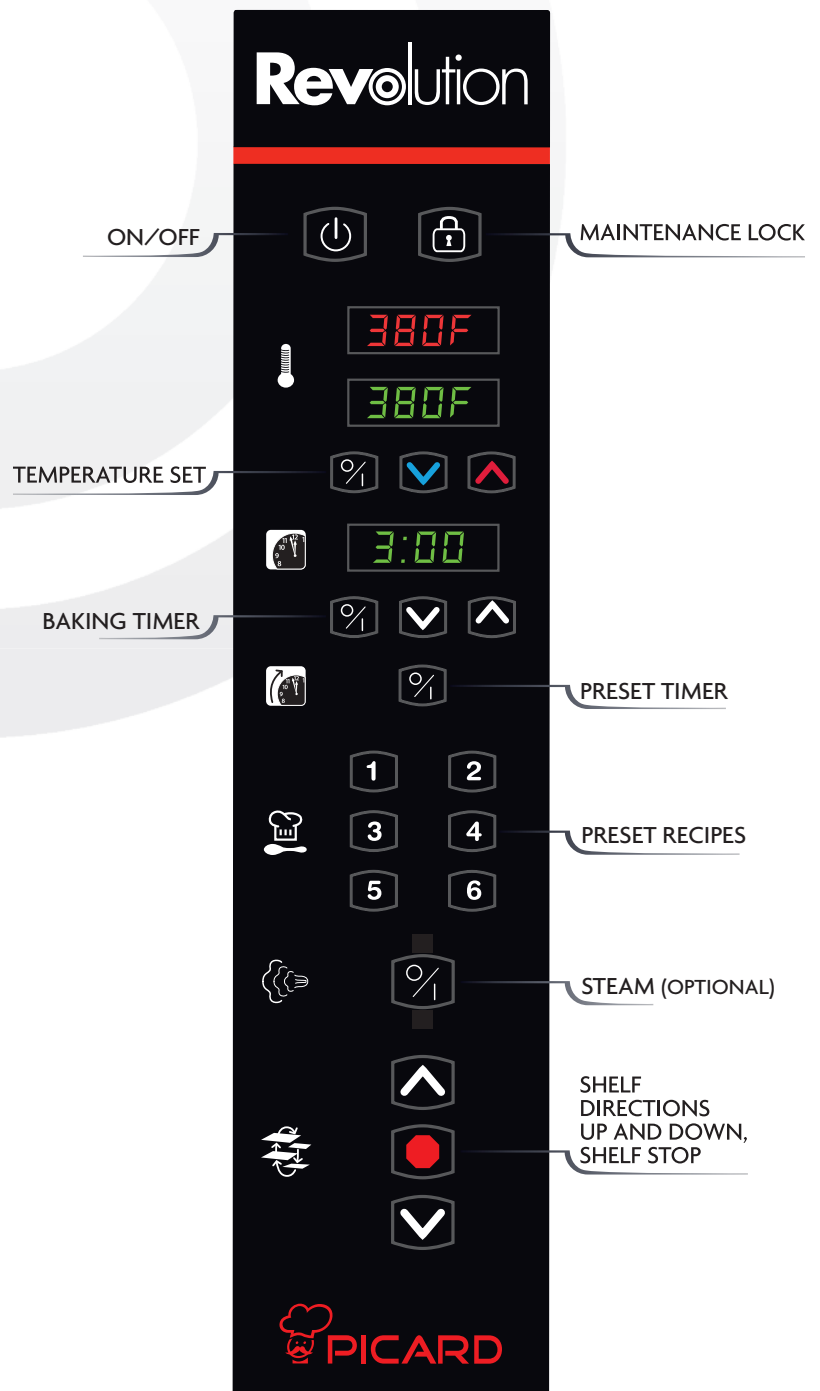

Technical Information

Powermax system

- | Picard ovens unique system
 - | Maintains constant temperature
 - | Maximum energy output
 - | Powerful
 - | Silent
 - | Maintenance free
 - | Clean burning
-

Aeromax ventilation system

- | Double directional ventilation (front and back)
 - | Permits equal baking
 - | Factory adjusted but permits special adjustments at the clients local
 - | Special system for better performance
 - | Bakes faster
-

Direct flame burner with air blower which brings in primary and secondary air for combustion to eliminate negative pressure problems. We will not use a perforated pipe as the main component of the burner but a burner made of knit metal fiber which has exceptional flame stability and heat insulation performance. This burner never goes out while in operating mode, the flame goes up and down adjusting to the required temperature.

Other features

- | Single point ventilation through the exhaust hood eliminating negative pressure problems. Requires a ventilation motor on the building's roof (purchaser expense)
 - | Digital control panel
 - | Aluminized steel interior walls and roof
 - | All carbon-graphite bushings for mobile parts
 - | Choice of either full steel or expanded metal shelves; optional baking stone shelves imbedded inside shelf structure available
-

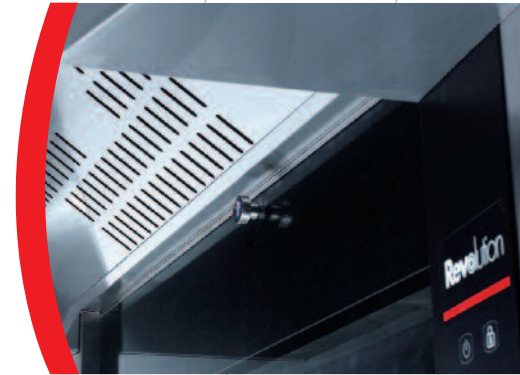

Revolution

REVOLVING TRAY OVENS

FRONT VIEW

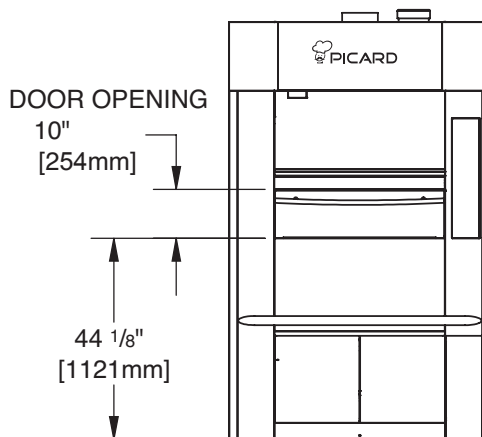
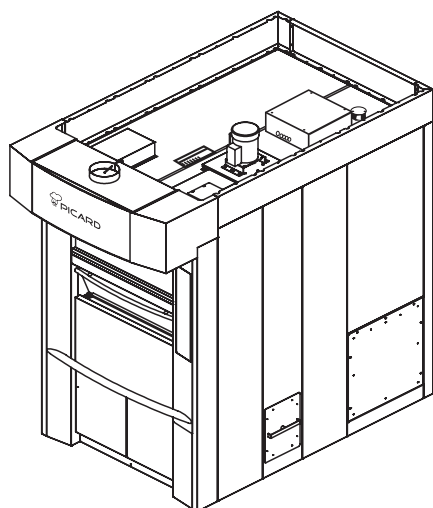

TOP VIEW

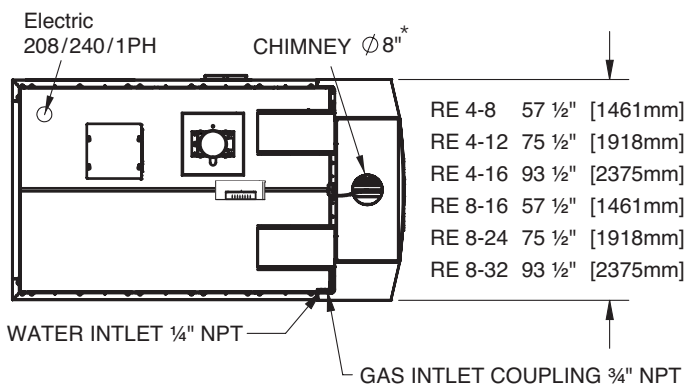

SIDE VIEW

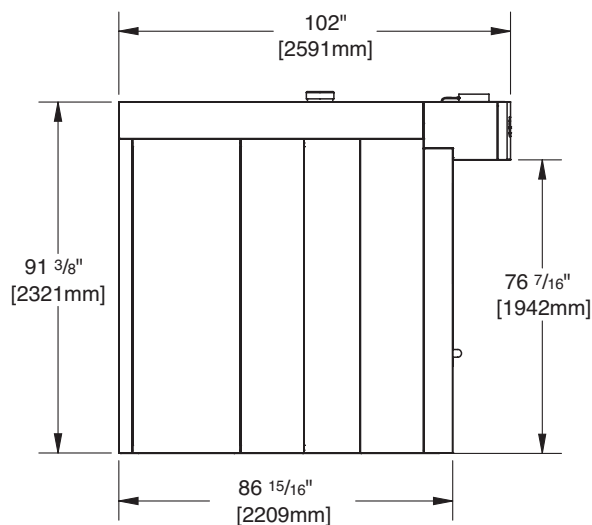

- Also available in electric models Specification data upon request
- * Requires duct and a ventilator motor, roof mount or wall mount depending upon your installation. AT THE CUSTOMER'S RESPONSIBILITY AND COST



RECOMMENDED MINIMUM CLEARANCES

Floor to ceiling	Side and back to wall	Floor	Manhole side
96"	0"	Approved for combustible surface	24"



GAS SUPPLY SPECIFICATIONS

	Minimum gas pipe size	Line pressure	Power (BTU/HR)					
			RE 4-8	RE 4-12	RE 4-16	RE 8-16	RE 8-24	RE 8-32
Natural Gas	3/4" NPT	5"-14" W.C.	150,000	200,000	250,000	150,000	200,000	250,000
Propane Gas	3/4" NPT	5"-14" W.C.	150,000	200,000	250,000	150,000	200,000	250,000

ELECTRICAL RATING

Model	Voltage	Phase	Hertz	Amps	Supply
RE 4-8	208-240V	1	60	9	3 wires including ground
RE 4-12				9	
RE 8-16				9	
RE 8-24				9	
RE 4-16				12	
RE 8-32				12	

SHIPMENT INFORMATION

Model	Ship weight (1)	Crate dimensions		
RE 4-8	2,500 lbs	64"	92"	88"
RE 4-12	3,000 lbs	83"	92"	88"
RE 4-16	3,800 lbs	90"	100"	88"
RE 8-16	2,800 lbs	64"	92"	88"
RE 8-24	3,300 lbs	83"	92"	88"
RE 8-32	4,300 lbs	90"	100"	88"

(1) Steam (option) included.

BAKING CAPACITIES

Trays			Bagels	Breads			Pies	Pizzas					
Model	Qty	Size	5 oz	Pans (18" x 26")			9"	8"	10"	12"	14"	16"	18"
RE 4-8	4	26" x 36 1/2"	120	8	60	48	36	44	24	16	12	8	8
RE 4-12	4	26" x 54 1/2"	180	12	90	72	54	66	36	24	18	12	12
RE 4-16	4	26" x 72 1/2"	240	16	120	96	72	88	48	32	24	16	16
RE 8-16	8	26" x 36 1/2"	240	16	120	96	72	88	48	32	24	16	16
RE 8-24	8	26" x 54 1/2"	360	24	180	144	108	132	72	48	36	24	24
RE 8-32	8	26" x 72 1/2"	480	32	240	192	144	176	96	64	48	32	32

* Continuous product development is a Picard policy. Therefore, we reserve the right to change specifications and/or design without prior notice.

NEW BAKING REVOLUTION



With our new ultra pure euro-line of products and our specialists to assist you in your choice, we can certainly contribute even more to the success of your company and your projects. Do not hesitate to contact us and see how you can exploit our services more and at the same time, simplify your life.

You'll see. We will ignite your future!

The Oven **Revolution** hybrid

-  Compact size
-  Versatile
-  Self generating steam
-  Economical
-  Low maintenance

VISIT OUR WEB SITE:
WWW.PICARDOVENS.COM



PICARD

Picard Ovens, Inc.



Intertek
9700551



Intertek



Picard Ovens Inc. continuously improves their products and reserves the right to change specifications without notice.

Printed in Canada

ENERGY  **SMART**

Your authorized dealer:

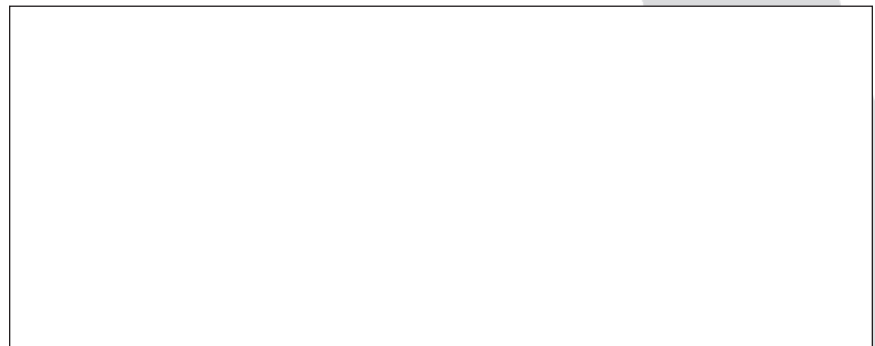

1325 Notre-Dame Est, Victoriaville, QC, Canada G6P 4B8
T 819 758-1883 / 1 800 668-1883 F 819 758-1465